



Project:
Item:
Quantity:

**MINI JUMBO
VACUUM PACKAGING MACHINE**



FEATURES

- Seal bar length: 11"
- Seal bar with two wires, for double security
- Seal bar easily removable for cleaning and maintenance purposes
- Pump capacity: 169 cf (5 m³/h) Busch vacuum pump
- Pump maintenance and cleaning program
- Machine cycle: 25-60 sec
- Time control 1- 99 sec
- Transparent High hood lid: 5", which opens automatically after every cycle
- Deep drawn vacuum chamber
- Comes with insert plates for a faster cycle and product adjustment
- Stainless steel exterior
- 6ft cord with Nema 5-15P plug
- Standard with service kit

DESCRIPTION

The robust, stainless steel Mini Jumbo vacuum packer is standard equipped with a Busch vacuum pump. The machine is ETL listed and complies with UL, CSA and CE standards.

OPTIONS AND ACCESSORIES

- Cut-off/Wide seal
- Inclined insert plate
- Food container adaptor
- Cart with castors and shelf



WARRANTY

Henkelman Inc offers a warranty of 1 year on labor and 3 years on parts. For full warranty details, please refer to www.henkelman.com.

DATE

APPROVAL



FIT FOR FOOD SERVICE
WWW.HENKELMAN.COM

HENKELMAN INC.
493 W Fullerton Ave
Elmhurst IL, 60126

Sales and technical support
P +1 331 979 2013
F +1 630 359 3875
E info@henkelmanusa.com
Service and warranty
P +1 844 208 5685

VACUUM PACKAGING MACHINE MINI JUMBO – SPEC SHEET

VACUUM PACKING MACHINE MINI JUMBO – SPECS

VACUUM PACKING MACHINE MINI JUMBO – SPEC SHEET

DIMENSIONS

In inches

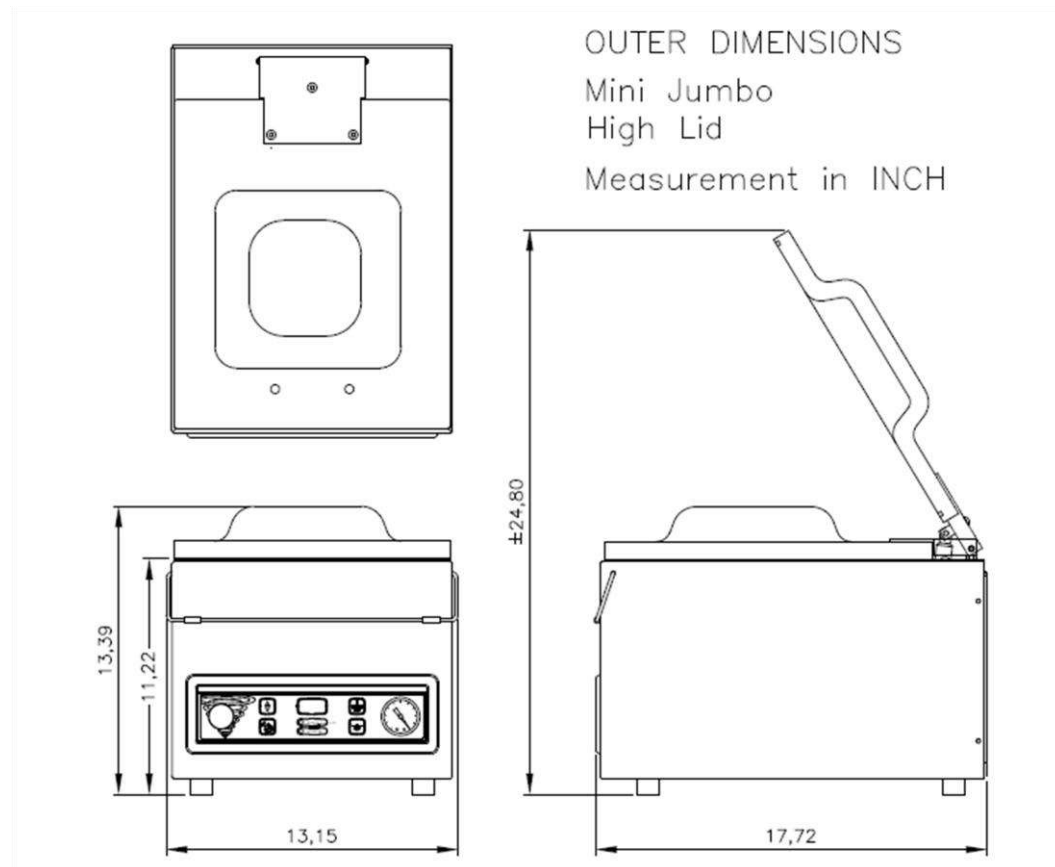

Model	Dimensions (inches)		Volts	Amps	Hz	Pump capacity	HP	Plug	Weight (lbs)
	Chamber (usable space) (LxWxH)	Machine (LxWxH)							
Mini Jumbo	12"x11"x5"	17.7"x13.2"x13,4"	110-120V	6.5	60Hz	169 cf/h (5 m ³ /h)	0.4	NEMA 5-15P	57



FIT FOR FOOD SERVICE
WWW.HENKELMAN.COM

HENKELMAN INC.
493 W Fullerton Ave
Elmhurst IL, 60126

Sales and technical support
P +1 331 979 2013
F +1 630 359 3875
E info@henkelmanusa.com
Service and warranty
P +1 844 208 5685