

USER MANUAL

Vacuum Packing Machine

Jumbo series



Art nr 0894606

© Copyright 2014

No part of this publication may be reproduced, stored in a retrieval system, or transmitted in any form or by any electronic or mechanical means, or by photocopying, recording, or otherwise without the prior written consent of Henkelman BV.

INTRODUCTION

Henkelman BV is a supplier of ultra-modern vacuum packing machines.

Our machines are designed and manufactured to the highest standards. And that's clear. They combine a sleek built and functional design with ease of use and durability. Installation is just a matter of 'plug & pack' and the clever design ensures that the hygiene standards are maintained at all times.

This manual contains relevant information and instructions for installation, operation and maintenance of the machine.



- The machine is not suitable for the packaging of toxic, corrosive, irritant or hazardous materials
- All persons responsible for the operation must at least fully read and understand the chapters on operation and safety of these operating instructions
- All persons responsible for assembly, installation, maintenance and/or repair should read and understand all of these instructions
- The user is responsible for the interpretation and use of this manual in any circumstances. Please contact the owner or the manager in case of questions or doubts about the correct interpretation
- This manual should be kept near the machine and should be within reach for users
- All major maintenance, adjustments to the machine and observations should be recorded in a log, see Appendix 10.1
- Changes to the installation/machine are not permitted without prior written approval of the supplier
- Please contact the vendor for special servicing that is not included in this manual
- Comply at all times with the safety requirements, as specified in Chapter 3
- The proper functioning and safety of the system can only be guaranteed if the recommended maintenance is executed on time and correctly
- Illustrations may differ from your machine



Conforms to
ANSI/UL Std. 963
Conforms to
ANSI/NSF 169
Certified to
CAN/CSA Std. C22.2 No.68



TABLE OF CONTENTS

LIST OF FIGURES.....	5
EC DECLARATION OF CONFORMITY (COPY)	6
LIST OF SYMBOLS.....	7
ICONS	8
1. TECHNICAL INFORMATION.....	9
2. DESCRIPTION OF THE MACHINE.....	10
2.1. DESCRIPTION OF THE PACKAGING PROCESS / MACHINE FUNCTIONS	11
2.1.1. THE PACKAGING PROCESS / MACHINE FUNCTIONS	11
2.1.2. GENERAL FUNCTIONS	12
2.2. THE SEAL SYSTEM.....	12
2.3. DE VACUUM PUMP	14
2.4. ELECTRICAL INSTALLATION.....	16
2.5. SINGLE PROGRAM DIGITAL CONTROL (SPDC).....	17
3. SAFETY	19
3.1. GENERAL.....	19
3.2. DURING NORMAL OPERATION	20
3.3. OPERATIONAL STAFF	20
4. INSTALLATION	21
4.1. TRANSPORT AND PLACEMENT	21
4.2. CONNECTING THE MACHINE.....	21
4.3. START THE MACHINE FOR THE FIRST TIME	21
5. OPERATION	22
5.1. STARTUP	22
5.2. PRODUCTION.....	22
5.3. CONTINUE TO THE NEXT STEP OF THE CYCLE.....	23
5.4. STOP PROGRAM.....	23
5.5. CHANGING THE PROGRAM SETTINGS	24
5.5.1. SINGLE PROGRAM DIGITAL CONTROL (SPDC).....	24
5.5.1.1. EXTERNAL VACUUM OPTION (SPDC).....	25
5.6. DIRECTIVE FOR FUNCTION VALUES	26
6. MAINTENANCE.....	28
6.1. MAINTENANCE DIAGRAM	28
6.2. CLEANING THE MACHINE	29
6.3. OIL CLEANING PROGRAM	30
6.4. ADD OIL / CHANGE OIL	30
6.5. REPLACING THE EXHAUST FILTER (MAINTENANCE OF VACUUM PUMP)	32
6.6. REPLACING THE SEALING WIRE.....	35
6.7. REPLACING THE SILICONE RUBBER ON THE SILICONE HOLDERS.....	37
6.8. REPLACING THE LID GASKET	38
7. TROUBLESHOOTING.....	39
8. WARRANTY CONDITIONS.....	40
8.1. LIABILITY	40
8.2. WARRANTY	40
9. DISPOSE AS WASTE	41
10. APPENDIX.....	42
10.1. Log.....	42

LIST OF FIGURES

FIGURE 1: OVERVIEW OF THE MAIN COMPONENTS.....	10
FIGURE 2: OVERVIEW OF THE SEAL SYSTEM	12
FIGURE 3: OVERVIEW OF THE PUMP (FILTER COVER REMOVED)	15
FIGURE 4: OVERVIEW OF THE ELECTRICAL INSTALLATION	16
FIGURE 5: CONTROL PANEL SINGLE PROGRAM DIGITAL CONTROL (SPDC)	17
FIGURE 6: CHANGING PARAMETERS (SPDC).....	24
FIGURE 7: EXTERNAL VACUUM ADAPTER KIT (SPDC).....	25
FIGURE 8: WATER VAPOUR LINE	27
FIGURE 9: REPLACING THE EXHAUST FILTER ON A 3-4 M ³ PUMP	32
FIGURE 10: REPLACING THE EXHAUST FILTER ON A 8M ³ POMP	33
FIGURE 11: REPLACING THE EXHAUST FILTER ON A 16M ³ POMP	34
FIGURE 12: REMOVING THE SEAL BAR	35
FIGURE 13: REPLACING THE SEALING WIRE	35
FIGURE 14: REPLACING THE SILICONE RUBBER OF THE SILICONE HOLDERS	37
FIGURE 15: REPLACING THE LID GASKET	38

EC DECLARATION OF CONFORMITY (COPY)

We,

Henkelman BV
Titaniumlaan 10
5221 CK, 's Hertogenbosch
Nederland

declare under our sole responsibility that the product;

Machine type: Jumbo Series

fulfils all the relevant provisions of the directives

2006/42/EG Machinery Directive
2004/108/EG EMC-Directive

and is in conformity with the following standard(s) or other normative document(s);

NEN-EN-ISO 12100	Safety of machinery - general principles for design – Risk assessment and risk reduction
NEN-EN 13857	Safety of machinery – Safety distances to prevent hazard zones being reached by upper and lower limbs
NEN-EN 349	Safety of machinery – Minimum gaps to avoid crushing of parts of the human body
NEN-EN 953	Safety of machinery – Guards - General requirements for the design and construction of fixed and movable guards
NEN-EN 13849-1	Safety of machinery – Safety-related parts of control systems - Part 1: General principles for design
NEN-EN 60204-1	Safety of machinery – Electrical equipment of machines - Part 1: General requirements

The undersigned is authorized to compile the technical file

Netherlands, 's-Hertogenbosch, 28 februari 2014

Stephan Harleman

Director

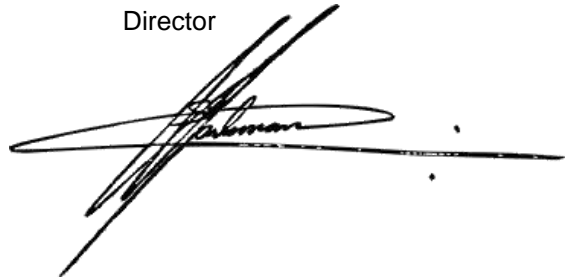

LIST OF SYMBOLS

For all operations in which the safety of the operator and/or technician is at stake and where caution should be exercised, the following symbols are used.



Caution!









Danger:
High Voltage!

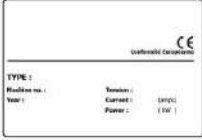

Tip:
Provides a quick overview or offers tips to make it easier to perform certain actions

ICONS

Some icons and warnings are included on the machine among others to indicate the possible risks involved to the users.

ICON	DESCRIPTION	LOCATION
	Nameplate	At the rear of the machine
 WARNING HAZARDOUS VOLTAGE. Contact may cause electric shock or burn. This unit is to be serviced by trained personnel only.	Warning sign "HIGH VOLTAGE"	At the rear of the machine
 CAUTION To provide continued protection against risk of electric shock, connect to properly grounded outlets only	Warning sign "SHOCK RISK"	At the rear of the machine
 CAUTION Hot Surface. Avoid Contact.	Warning sign "HEAT"	On the housing of the machine
	Warning sign "HEAT"	<ul style="list-style-type: none"> • On the sealbar(s) • On the vacuum pump
	<p>CAUTION! Regularly check that the icons and markings are still clearly recognizable and legible. Replace them if this is no longer the case</p>	

1. TECHNICAL INFORMATION

Jumbo	Mini Jumbo	Jumbo Plus	Jumbo 30	Jumbo 35	Jumbo 42	Jumbo 42XL	Jumbo 42XXL	
General								
Ambient temperature	41 - 86	41 - 86	41 - 86	41 - 86	41 - 86	41 - 86	41 - 86	°F
Noise production	< 70	< 70	< 70	< 70	< 70	< 70	< 70	dB(A)
Maximum daily production	5*	5*	5*	5*	5*	5*	5*	h/day
Dimensions of the machine								
Width	13.2	13.2	17.7	17.7	19.4	19.4	19.4	inch
Length	17.7	17.7	21.8	21.8	20.8	24.3	24.3	inch
Height	12.0 / 13.4**	12.0 / 13.4**	14.4	15.9	17.3	18.5	18.5	inch
Weight	55.1	66.1	77.2	105.8 ***	123.5 ***	147.7 ***	155.6 ***	lbs
Maximum product height								
	3.3 / 5.1**	3.3 / 5.1**	5.9	5.9	7.1	7.1	7.1	inch
Electrical connection								
Tension	****	****	****	****	****	****	****	V
Power	****	****	****	****	****	****	****	kW
Vacuum pump								
Capacity	4.8	9.6	9.6	19	19	19	24	m ³ /h
Oil	0.06	0.25	0.25	0.3	0.3	0.3	0.5	liter
Oil type (Ambient temperature 41-104°F)	VM22	VM32	VM32	VM32	VM32	VM32	VM32	

* This machine is not designed for continuous use; The maximum used setting for vacuum should be 60 seconds, you have to respect a 15 seconds waiting period between each following cycle. Next to that if the machine is used for 1 hour continuous, the machine should be switched off, until the temperature of the enclosure has reached the ambient temperature

** Depending on lid type. High or low lid

*** Extensions legs are available for these machines. These legs will add 4 inch to the total height

**** See the nameplate

2. DESCRIPTION OF THE MACHINE



FUNCTION

- This chapter provides an overview of the main components and functions. If detailed information is available in this guide, you will be redirected to the specific sections.
- The performance of your machine may differ from the figure below.

The figure below shows the main components of the system:

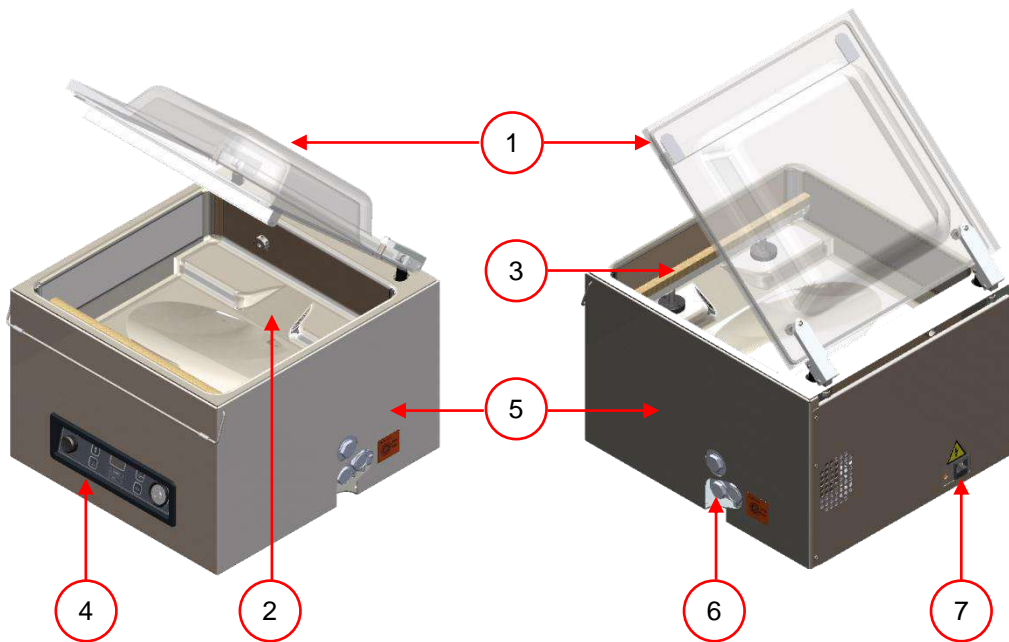

Figure 1: Overview of the main components

NO.	PART	DESCRIPTION	SECTION
1	Lid	<ul style="list-style-type: none"> • The function of the lid is to close the chamber during the vacuum cycle • The lid has a lid gasket fitted, which makes sure the machine does not leak during the vacuum cycle • In the lid, silicone holder(s) are mounted as the opposite of the sealing bar(s) 	6.8 2.2, 6.7
2	Chamber	<ul style="list-style-type: none"> • The products to be packed will be placed on the worktable / in the chamber with the opening of the vacuum seal bag on the seal position 	
3	Seal bar	<ul style="list-style-type: none"> • In the chamber, depending on the version, 1 or 2 seal bars are mounted. With this/these the vacuum bag is closed 	2.2, 6.6

NO.	PART	DESCRIPTION	SECTION
4	Controlpanel	<ul style="list-style-type: none"> See section 	2.5
5	Machine housing	<ul style="list-style-type: none"> The machine frame contains all necessary parts for the correct functioning of the machine 	
6	Vacuum pump	<ul style="list-style-type: none"> See section 	2.3
7	Power connection	<ul style="list-style-type: none"> See section 	2.4

2.1. Description of the packaging process / machine functions



FUNTION

- This chapter provides an overview of the process and the available machine functions
- In chapter 5.5 you will find information on how to set the parameters to the correct values

2.1.1. The packaging process / machine functions

The following steps are taken during the process. For the detailed procedure, see Chapter 0

STEP	PROCESS PHASE	OPERATION
1	Preparations	<ul style="list-style-type: none"> The operator puts the product in a vacuum bag and places it on the work top with the opening on the seal bar
2	Extracting Vacuum	<ul style="list-style-type: none"> The vacuum process is started by closing the lid During the cycle, the air will be removed from the chamber until the set time has been reached
3	Sealing	<ul style="list-style-type: none"> The seal bars are pressed against the contra bars, with the vacuum bag in between and melt the bag to be closed During the sealing, the material of the vacuum bag is heated and compressed to form a hermetic sealing. The function is programmed in seconds As an option, a cutting wire is available. The purpose of this wire is to remove the remaining foil from the excess flap
4	Releasing vacuum	<ul style="list-style-type: none"> The vacuum is released, by letting air back into the chamber

STEP	PROCESS PHASE	OPERATION
5	Open vacuum chamber	<ul style="list-style-type: none"> The lid opens
6	Remove the product	<ul style="list-style-type: none"> The operator can remove the packed product from the worktable

2.1.2. General Functions

FUNCTION	ICON	OPERATION
Cleaning the pump		<ul style="list-style-type: none"> The pump cleaning program allows for a proper flushing of the pump. During the program, the pump and the oil will reach the operating temperature, so that the oil and the fluid will be separated and that any contamination is filtered. The high temperature takes care of evaporation of moisture in the pump, which reduces the risk of corrosion
External vacuum		<ul style="list-style-type: none"> With this function vacuum can be applied to special food packaging gastronom containers outside the machine The possibilities for adjusting the vacuum value are equal to the standard vacuum (see 5.5.1.1 SPDC)

2.2. The seal system



FUNCTION

- The seal system closes the opening(s) of the bag(s) to maintain the vacuum and/or gas inside
- The remaining flap can optionally be cut off by the seal bar

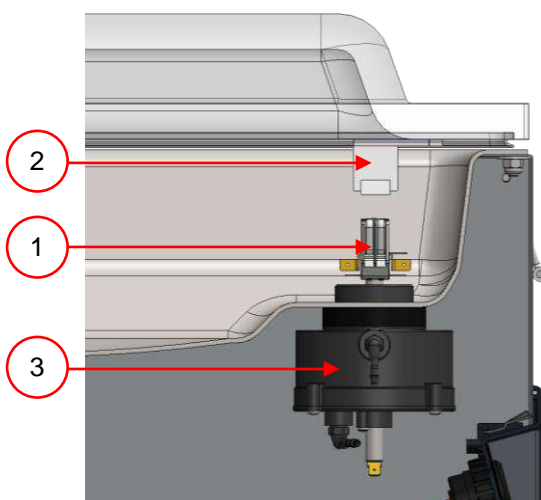

Figure 2: Overview of the seal system

NO.	PART	DESCRIPTION	SECTION
1	Seal bar	<ul style="list-style-type: none"> The seal bar consists of the following components <ul style="list-style-type: none"> Seal wires: the sealing wires are heated for a certain period of time so that the open side of the vacuum bag will melt together during the sealing Cutting wire (optional): a cutting wire is heated in such a way that the foil of the bag partially melts so that the top flap of the vacuum bag can be torn off easily Teflon-tape: sealing and cutting wires are coated with Teflon tape to prevent the bag to stick to the seal bar Refer to the indicated section for detailed information on maintenance 	6.6
2	Silicon holder	<ul style="list-style-type: none"> Opposite to each seal bar a silicone holder is mounted, which provides counter-pressure on the cylinders / seal bag 	6.7
3	Seal mechanism	<ul style="list-style-type: none"> The seal bars are pressed on the vacuum bag by using cylinders or seal bags By connecting the outside atmospheric pressure to the inlet of the cylinders, they will press the seal bar on the bag 	2.2

2.3. De vacuum pump



FUNCTION

The vacuum pump creates a vacuum in the chamber

3 en 4 m³

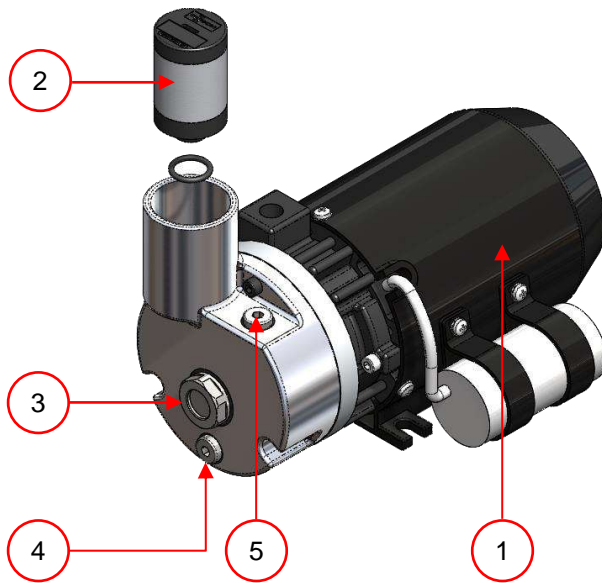

8 m³

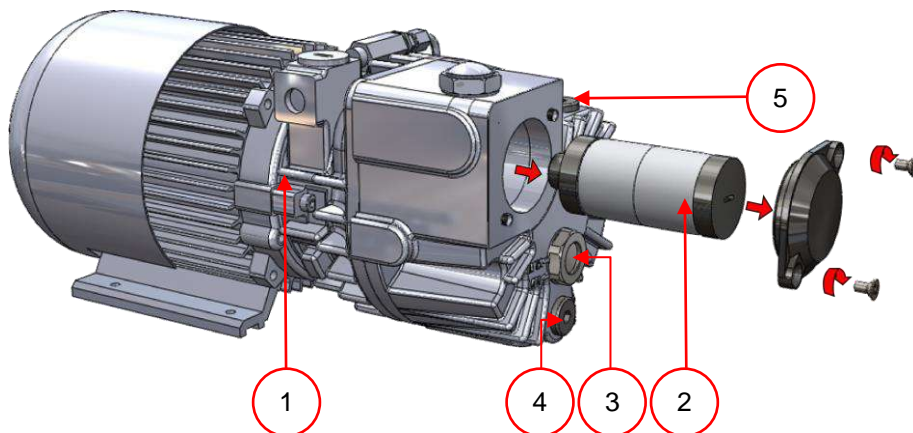

16 m³

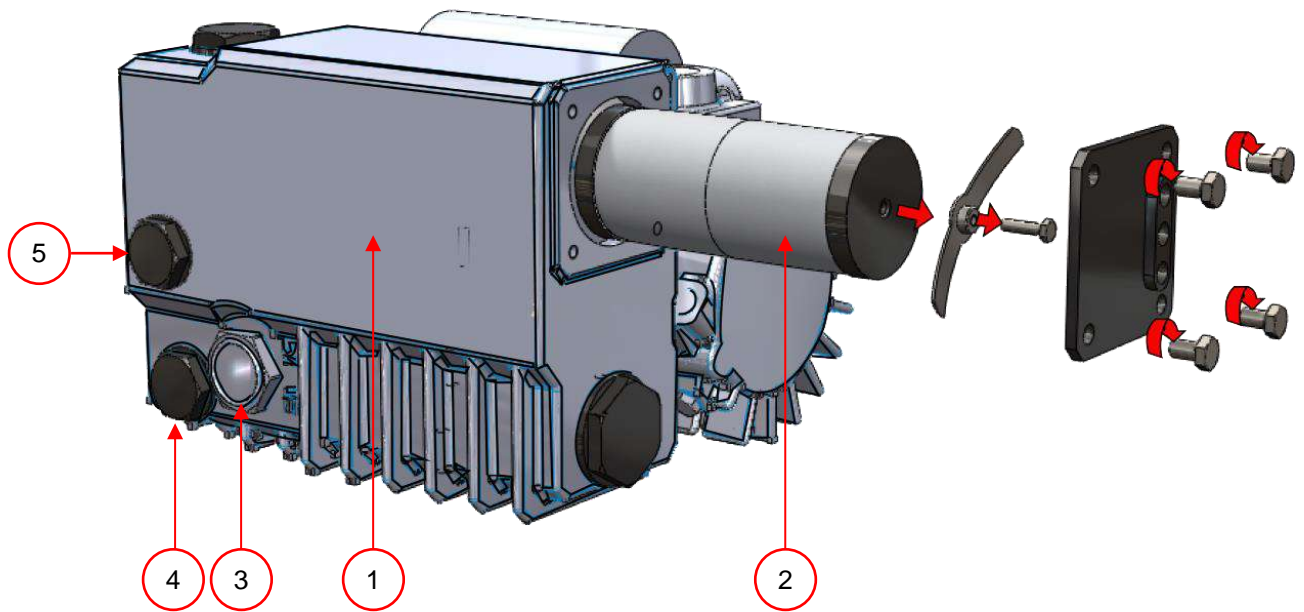

Figure 3: Overview of the pump (filter cover removed)

NO.	PART	DESCRIPTION	SECTION
1	Vacuum pump	<ul style="list-style-type: none">Creates the vacuum during the process	6.1
2	Exhaust filter	<ul style="list-style-type: none">Filters the exhaust air and absorbs oil vaporsRefer to the indicated section for detailed information with regards to maintenance	6.1
3	Oil sight glass	<ul style="list-style-type: none">The oil sight glass indicates the maximum and minimum oil level in the vacuum pumpThe oil sight glass is visible when the cover of the machine is in place	6.1
4	Oil drain plug	<ul style="list-style-type: none">To drain the oil	
5	Oil filler plug	<ul style="list-style-type: none">To fill the pump with oil	

2.4. Electrical installation



FUNCTION

- The electrical installation provides power to the vacuum pump, sealing system and control unit
- See the electrical diagram for the further structure and operation of the electrical installation. For the electrical diagram, please contact your dealer



ATTENTION!

- Work on the electrical installation may only be carried out by a technical expert
- When performing maintenance on the machine, always unplug the power cable to avoid electrical shock
- The machine should always be connected to a proper grounded outlet

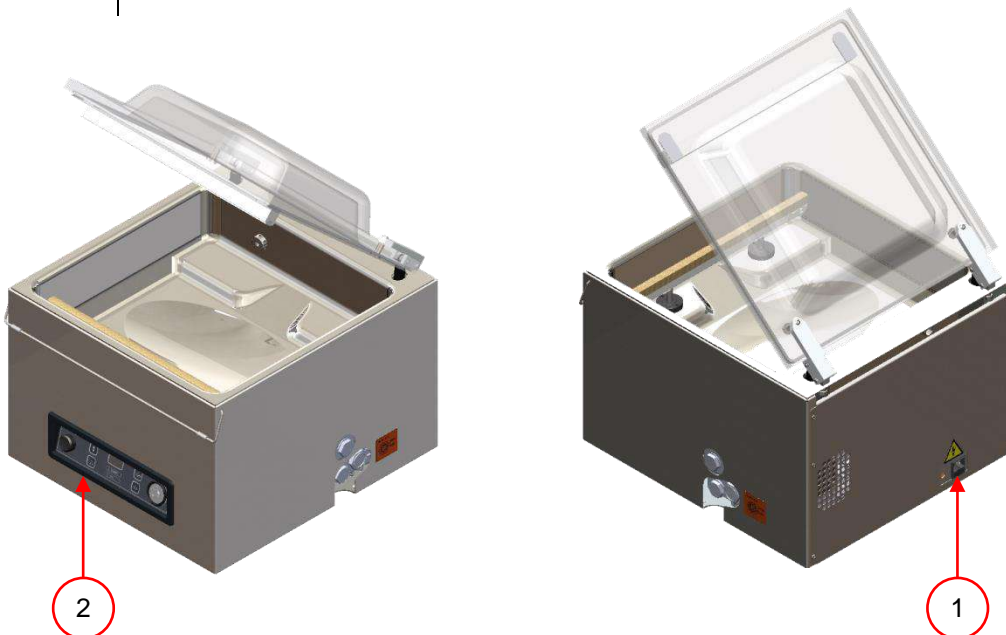

Figure 4: Overview of the electrical installation

The machine consists of the following components

NO.	PART	DESCRIPTION	SECTION/ LOCATION
1	Power cable	<ul style="list-style-type: none"> • To connect the power supply to the machine 	
2	Control panel	<ul style="list-style-type: none"> • The available control functions can be used • Your machine has the following control type: <ul style="list-style-type: none"> ○ Single Program Digital Control (SPDC) 	2.5

2.5. Single Program Digital Control (SPDC)



FUNCTION

- The machine can be operated
- The program can be modified
- See chapter 0 for instructions on operation and programming

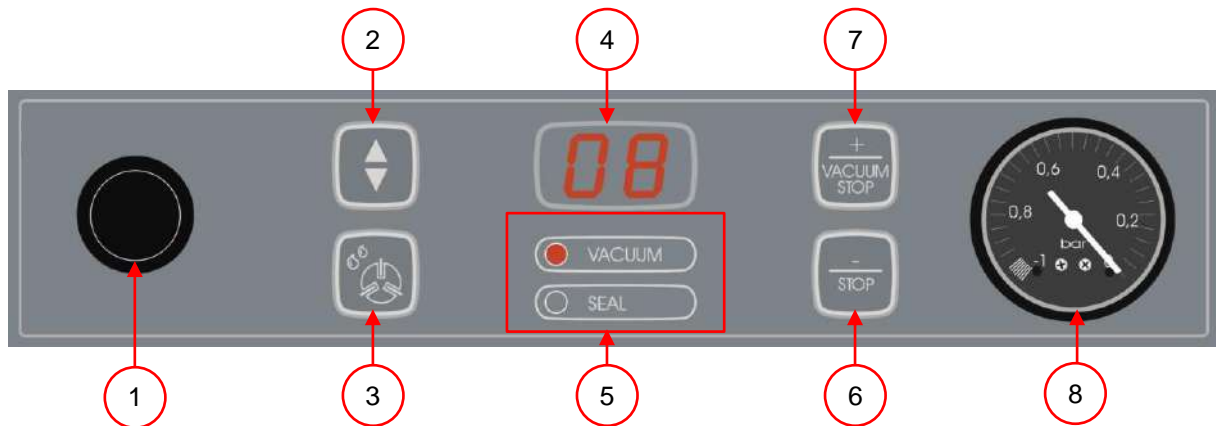

Figure 5: Control panel Single Program Digital Control (SPDC)

NO.	ELEMENT	EXPLANATION
1	On / Off button	<ul style="list-style-type: none"> • This button turns the machine on/off
2	Cursor key	<ul style="list-style-type: none"> • Navigates you through the functions shown in the display 4/5
3	"Oil cleaning program" key	<ul style="list-style-type: none"> • Operate the key to activate the pump cleaning program. This removes moisture from the oil in the vacuum pump. Moisture can be absorbed by the oil when the pump is only running short cycles or when you pack products containing moisture • See 6.3 for instructions
4	Display parameter	<ul style="list-style-type: none"> • Displays the current value of the active function during the program cycle or the set value of the selected function when the machine is idle
5	Function display	<ul style="list-style-type: none"> • The LED light for the function illuminates when the function is active during the program cycle or when the function is selected in the programming mode
6	"-/stop" key	<ul style="list-style-type: none"> • The 'stop' key can be used during a packing cycle to interrupt the full cycle. All functions are cancelled, and the cycle will be terminated • In the programming mode this key decreases the value of the selected parameter

NO.	ELEMENT	EXPLANATION
7	“+/stop vacuum” key	<ul style="list-style-type: none"> • Stops the current function and continues with the next program step • In the programming mode this key decreases the value of the selected parameter
8	Vacuum gauge	<ul style="list-style-type: none"> • Shows the pressure in the vacuum chamber • A value of -1 bar corresponds to 99% vacuum

3. SAFETY

3.1. General



ATTENTION!

- Never pack products that can be damaged by vacuum
- Never pack living animals
- Warranty and/or liability expires if any damage is caused by repairs and/or modifications that are not authorized by the supplier or any of its distributors
- In case of malfunction, contact the supplier
- High pressure cleaning is not allowed. This can cause damage to the electronics and other components
- Prevent water from entering the ventilation inlet of the chamber or through the vent of the pump. This causes irreversible damage to the pump
- The work space around the machine must be safe. The owner of the machine must take the necessary precautions to operate the machine safely
- It is forbidden to start the machine in an explosive environment
- The machine was designed in such a way that production is safe under normal ambient conditions
- The owner of the machine must check that the instructions in this manual are monitored effectively
- The securing devices must not be removed
- The correct operation and safety of the system can only be guaranteed when the maintenance is performed correctly and on time, as prescribed
- If work on the machine must be carried out, it must be disconnected and blocked from the power supply
- The housing of the machine may be hot after usage



DANGER

- Only authorized persons, designated by the owner, may perform work on the electrical installation
- Ensure, by means of internal procedures and monitoring, that all relevant power supplies are disconnected, to avoid electrical shock
- The machine should not be used during cleaning, inspection, repair and maintenance and must be disconnected from the power supply using the plug
- Never perform welding work on the machine without disconnecting the cable connection to the electrical components first
- Never use the power supply of the control unit to connect to other machines
- All electrical connections must be connected to the terminal strip according to the wiring diagram
- The machine should always be connected to a proper grounded outlet

3.2. During normal operation



ATTENTION!

- Before starting, ensure that no work is done on the system and that it is ready to use the machine
- Unauthorized persons must not operate the machine. Checking this is the task of the machine operator(s)
- Please immediately contact the service technician of your technical department or dealer if there are any changes, such as a poorly fitting lid, unusual vibrations or unusual noise
- Components of the seal system can reach high temperatures. Contact with these parts could cause injury
- The housing of the machine may be hot after usage

3.3. Operational staff



ATTENTION!

- Operating personnel must be 18 years or older
- Only authorized persons will be allowed to perform work on or with the machine
- Only work for which one is trained should be performed. This applies to maintenance and normal use
- The machine may only be operated by trained personnel
- Operating personnel must be familiar with all situations, so that in case of an emergency quick and effective action can be taken
- If an operator notices errors or risks or disagrees with security, he/she should report that to the owner or manager
- Safety shoes are mandatory
- Appropriate clothing is required
- Everyone must follow the safety rules as one can pose a danger to themselves and others. Always follow the work instructions strictly
- The housing of the machine may be hot after usage

4. INSTALLATION



EXPLANATION

Refer to chapter 1: Technical information for the correct specifications

4.1. Transport and placement



ATTENTION!

- The machine must be moved and transported upwards
- Place the machine on a flat, level surface. This is essential for trouble-free operation of the machine
- Machines with a plastic cover should not be placed near a heat source
- There must be enough space around the machine for proper ventilation. The space must be at least 15 centimeters
- Observe the instructions in Chapter 3 for all work to be performed. Failure to follow or ignore this may result in serious injury
- Make sure the machine housing is present and correctly fitted

4.2. Connecting the machine



ATTENTION!

- Make sure that the voltage indicated on the machine plate corresponds to the mains voltage
- Attach the appropriate plug on the cable in accordance with local laws and connection data (see Chapter 1)
- Always connect the machine correctly to a grounded outlet to avoid fire or electric shock (earth is green/yellow)
- The power cord must always be free and nothing should be placed on it
- Replace the power cord immediately if damaged

4.3. Start the machine for the first time



ATTENTION!

- Make sure there is enough oil in the pump (Figure 3:4). If this is not the case, then fill the oil
- Start and use the machine (Chapter 0)

5. OPERATION



ATTENTION

Observe the instructions in chapter 3 for all work to be performed
Failure to follow or ignore this may result in serious injury



EXPLANATION

- It is possible to optimize a program for your products by changing the parameters of the program, see Chapter 5.5

5.1. Startup

NO.	WHAT TO DO	ACTION	RESULT
1	Turn on the power	<ul style="list-style-type: none">• Place the plug in the socket	The control is ready for use
2	Turn on the power	<ul style="list-style-type: none">• Place the plug in the socket	The control is ready for use

5.2. Production

NO.	WHAT TO DO	ACTION	RESULT
1	Make sure the machine is powered on	<ul style="list-style-type: none">• See chapter 5.1	
2	Place the 1 st product	<ul style="list-style-type: none">• Put the products in the vacuum bag• Place the bag on the work table. Ensure that the opening(s) are correctly placed on the sealing position(s)	
3	Start the process	<ul style="list-style-type: none">• Close the lid	The packing cycle starts

5.3. Continue to the next step of the cycle



EXPLANATION

For some products, it may be necessary to proceed to the next step of the packing cycle, before the vacuum time or the vacuum level is reached

NO.	WHAT TO DO	ACTION	RESULT
1	Go to the next step of the packing cycle	<ul style="list-style-type: none">Press “vacuum stop” (Figure 5:7)	The next step is started

5.4. Stop program



EXPLANATION

Programs such as the packing program, or the oil cleaning program can be stopped at any time

NO.	WHAT TO DO	ACTION	RESULT
1	Stop the program	<ul style="list-style-type: none">Press the “stop button” (Figure 5:6)	The program will be stopped and the vacuum chamber will be decompressed

5.5. Changing the program settings

5.5.1. Single Program Digital Control (SPDC)



EXPLANATION

This section describes how parameters can be modified and indicates the units and limits of the parameters

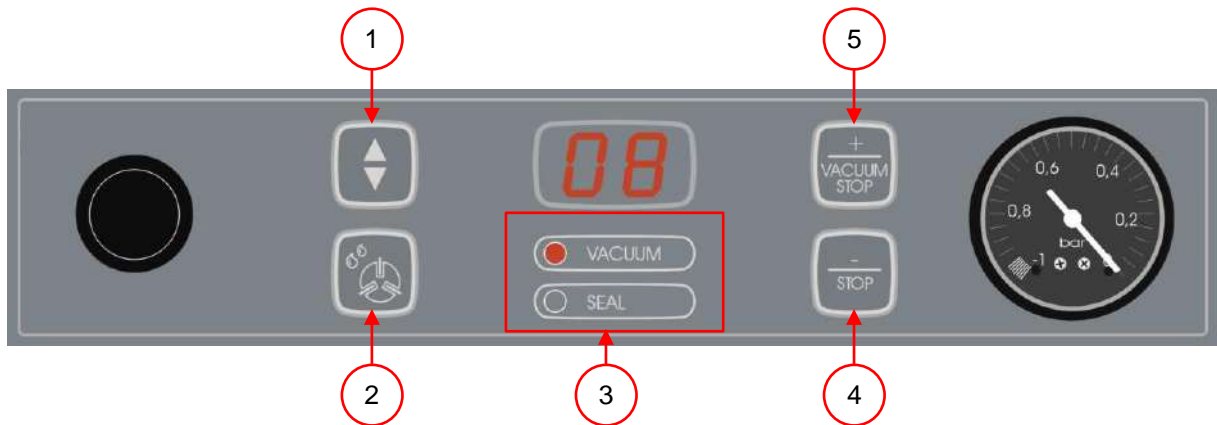

Figure 6: Changing parameters (SPDC)

NO.	WHAT TO DO	ACTION	RESULT
1	Select the parameter	<ul style="list-style-type: none"> Press the cursor key (Figure 6:1) to scroll through the parameters The LED in the program mode display (Figure 6:3) shows at which mode you are 	
2	Change the parameter	<ul style="list-style-type: none"> Press “+” or “-“ (Figure 6:5/4) to adjust the values The value is saved when you press the cursor key 	



EXPLANATION

To change a set value, the + and – buttons should be pressed and hold for a few seconds. This will prevent settings from being changed undesirably

5.5.1.1. External vacuum option (SPDC)



EXPLANATION

- With this function vacuum can be applied to special food packaging gastronorm containers outside the machine
- First check whether the container is resistant to a vacuum and can retain this

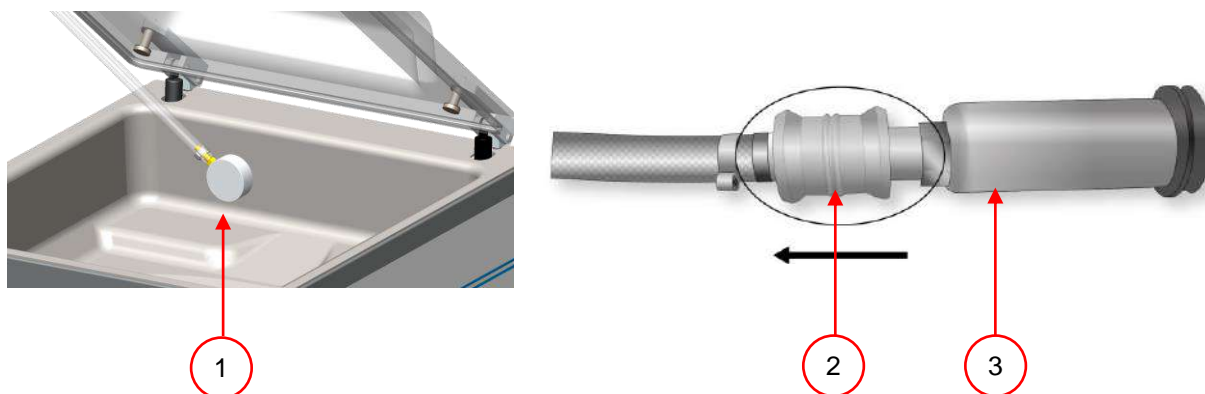

Figure 7: External vacuum adapter kit (SPDC)

NO.	WHAT TO DO	ACTION	RESULT
1	Select the external vacuum program	<ul style="list-style-type: none"> • Press the oil cleaning program key (Figure 6:2) • Press the cursor key (Figure 6:1) 	<p>“C” appears in the display</p> <p>“E” appears in the display</p>
2	Connect the external vacuum hose to the machine	<ul style="list-style-type: none"> • Place the adapter over the suction hole in the vacuum chamber (Figure 7:1) 	
3	Connect the external vacuum hose to the container	<ul style="list-style-type: none"> • Connect the vacuum hose adapter (Figure 7:3) on the valve of the container. And slide the valve (Figure 7:2) in the direction of the hose (closed position) 	
4	Start the process	<ul style="list-style-type: none"> • Press the “+” key 	Vacuum will be applied until the programmed value is reached
5	Stop the process when the desired vacuum is reached	<ul style="list-style-type: none"> • Press the “-” key 	Vacuum is stopped
6	Disconnect the external vacuum hose from the container	<ul style="list-style-type: none"> • Slide the valve of the adapter in the direction of the package (open position) and remove the hose 	Hose will be disconnected from the container and can be removed

5.6. Directive for function values



EXPLANATION

- For each function, values can be set if you are authorized as the owner. In order to understand the impact of the set value the table below explains the consequences of giving a low or high value for each function

FUNCTION	RANGE	CONDITIONS
Vacuum	2-700 mbar	<ul style="list-style-type: none"> • Rule of thumb: the higher the vacuum, the less oxygen remains in the package, so the product has a longer shelf life. There are exceptions to this rule • Average vacuum time is 30 - 45 seconds (depending on the volume of the product)
Seal time	0,1-4,0 sec	<ul style="list-style-type: none"> • This is the time in which the seal wire and/or cutting wire is heated. The longer the time, the more heat is being transferred to the bag • Average seal time is 1.8 - 2.5 seconds
Cleaning of the pump	15 minutes	<ul style="list-style-type: none"> • There are no settings possible (See 6.3)



ATTENTION!

The vacuum pressure in the chamber should be at least 30% at the time of sealing (0,7 bar on the gauge)



EXPLANATION

- When the pressure decreases, the boiling point of water is reduced (see Figure 8). This physical law can cause a product to boil. In addition to contamination of the machine, this provides for loss of weight and quality of the product to be packed
- When packing products that contain moisture such as soups and sauces, it is important to follow the vacuum process closely. At the moment that bubbles are formed or it starts to bubble, immediately proceed to the next step in the cycle (see section 5.3)
- By cooling the products as much as possible, before applying vacuum, a deeper vacuum can be achieved
- When packaging moisture containing products, it is important that the conditioning program is run at least 1 time per week. With daily vacuuming of moisture containing products, it is recommended to run the conditioning program at the end of the day

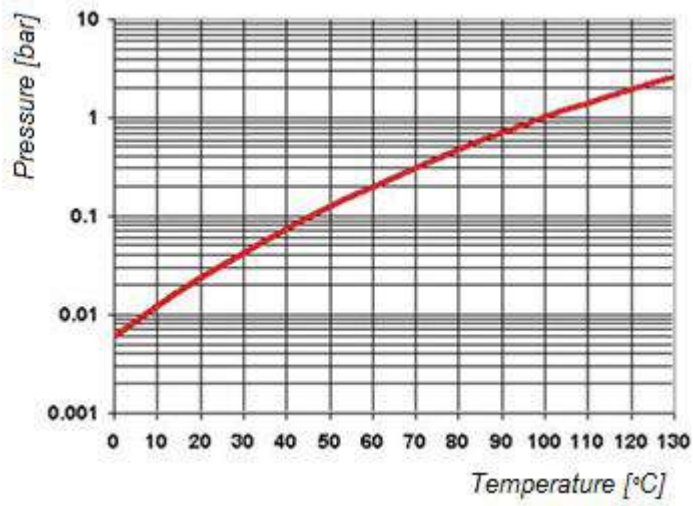

Figure 8: Water vapour line

6. MAINTENANCE



ATTENTION!

- Always disconnect the power supply by unplugging the power cord
- Test the machine after maintenance or repairs, so it is certain that the machine can be safely used
- Only trained personnel should perform the described maintenance work

6.1. Maintenance diagram

The diagram below shows the maintenance activities that must be performed.

ACTIVITY	LUBRICANT	Daily	Weekly	Every 6 months	Yearly	Every 4 years	SECTION
Cleaning							
Cleaning the machine							6.2
Lubrication							
Replace the oil of the vacuum pump	See chapter 1 for oil type						1
Inspecties							
Check the oil level							2.3
Execute the oil cleaning program							6.3
Inspect the seal bars							6.6
Inspect the silicone rubber of the silicone holders							6.7
Inspect the lid seal							6.8
Check the plastic lid for cracks							

ACTIVITY	LUBRICANT					SECTION
		Daily	Weekly	Every 6 months	Yearly Every 4 years	
Replacements						
Replace the sealing wires						6.6
Replace the silicone rubber of the silicone holders						6.7
Replace the lid seal						6.8
Replace the exhaust filter						6.5
Please contact your supplier for a professional service						
Replace the plastic lid						

6.2. Cleaning the machine



EXPLANATION

- It is not allowed to clean with a high pressure cleaning machine
- Do not use harsh or toxic cleaning materials
- Do not use cleaning materials with solvents

NO.	WHAT TO DO	ACTION	RESULT
1	Clean the machine	<ul style="list-style-type: none"> • You can clean the surfaces with a soft, damp cloth, or you can apply your cleaner to the machine and wipe it off with clean water 	

6.3. Oil cleaning program



EXPLANATION

- The oil cleaning program will let the vacuum pump run for 15 minutes. During the program, the pump and the oil will reach the operating temperature. The oil absorbs fluid in the pump. The high temperature ensures that the moisture evaporates in the pump and reduces the risk of corrosion
- If you pack moist products, such as soups or sauces, it is necessary to use the oil cleaning program more often than the prescribed interval of once a week

NO.	WHAT TO DO	ACTION	RESULT
1	Select the program	<ul style="list-style-type: none"> • Press the key for the oil cleaning program (Figure 5:3) 	
2	Start process	<ul style="list-style-type: none"> • Close the lid 	The oil cleaning program will be executed for 15 minutes

6.4. Add oil / change oil



WARNING

- The oil in the vacuum pump can be hot. When replacing the oil contact with hot oil may be possible



EXPLANATION

If the machine will not be used for long periods of time, the oil should be removed from the pump. This is because any moisture and dirt in the oil can affect the pump, causing the pump to jam at the next use

Add oil

NO.	WHAT TO DO	ACTION	RESULT
1	Add oil	<ul style="list-style-type: none">Remove the oil filler plug (Figure 3:5)Add oil until the oil level is between the "max" and "min" level (Figure 3:3)Place back the oil filler plug	

Replacing oil

NO.	WHAT TO DO	ACTION	RESULT
1	Change oil	<ul style="list-style-type: none">Place a drip pan under the oil drain plug (Figure 3:4)Remove the oil drain plug (Figure 3:4)Place back the oil drain plug	The oil drains from the pump
2	Fill with new oil	<ul style="list-style-type: none">Remove the oil filler plug (Figure 3:5)Add oil until the oil level is between the "max" and "min" level (Figure 3:3)Place back the oil filler plug	

6.5. Replacing the exhaust filter (maintenance of vacuum pump)



EXPLANATION

1. The exhaust filter prevents oil vapors to be emitted by the exhaust air from the vacuum pump
2. If the filter becomes saturated, it is no longer possible to reach maximum vacuum
3. Replace the filter in case of vacuum problems, or in accordance with the maintenance diagram of Chapter 6.1

3-4 m³ pump

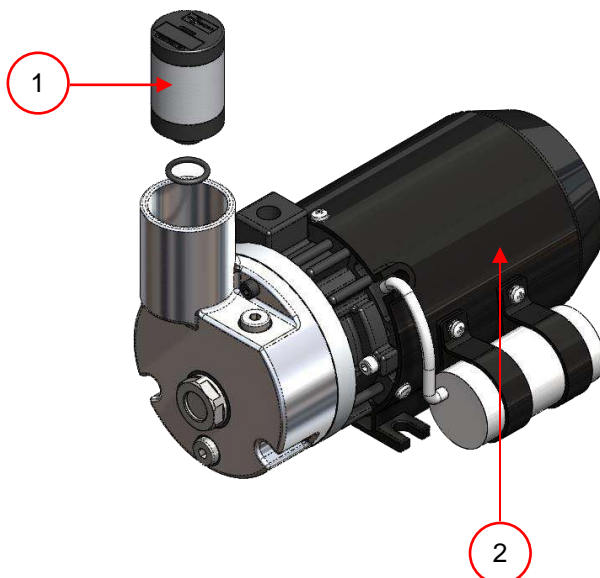

Figure 9: Replacing the exhaust filter on a 3-4 m³ pump

NO.	WHAT TO DO	ACTION	RESULT
1	Remove the exhaust filter	<ul style="list-style-type: none">• Screw the exhaust filter (Figure 9:1) out of the vacuum pump (Figure 9:2)	
2	Install the new filter	<ul style="list-style-type: none">• Screw the new filter in the vacuum pump• Make sure the O-ring is properly placed on the filter inlet	

8 m³ pump

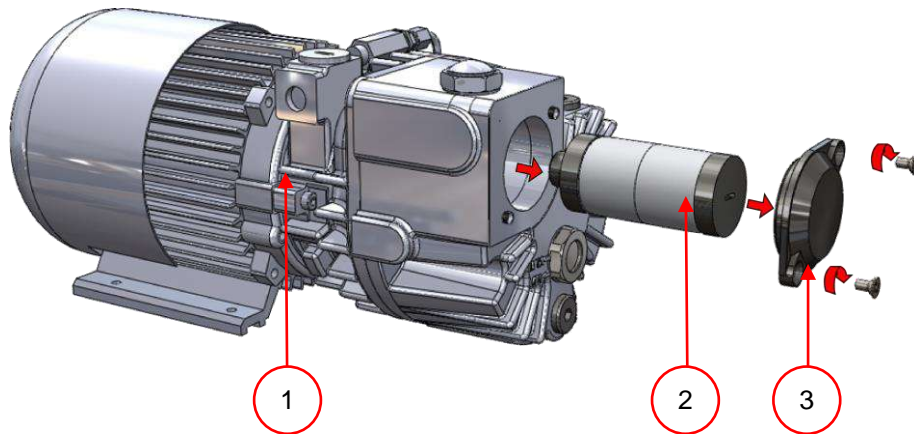

Figure 10: Replacing the exhaust filter on a 8m³ pump

NO.	WHAT TO DO	ACTION	RESULT
1	Remove the exhaust filter	<ul style="list-style-type: none">Remove the filter cover (Figure 10:3) from the vacuum pump (Figure 10:1)Screw the old filter (Figure 10:2) out of the vacuum pump	
2	Install the new filter	<ul style="list-style-type: none">Screw the new filter in the vacuum pumpMake sure the O-ring is properly placed on the filter inletInstall the filter cover	

16 m³ pump

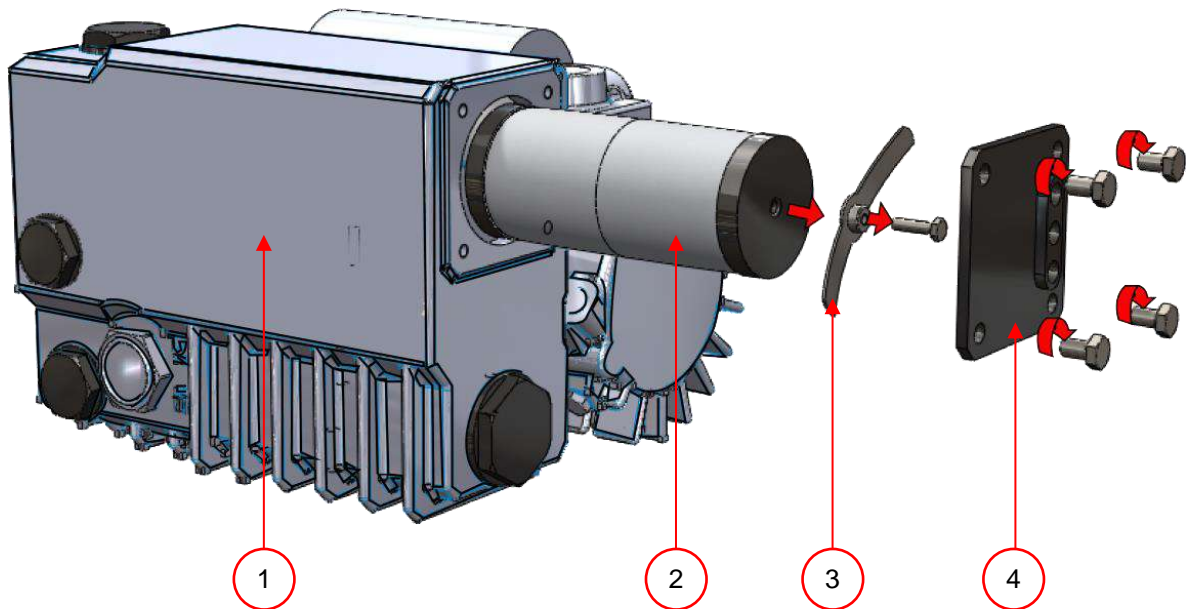

Figure 11: Replacing the exhaust filter on a 16m³ pump

NO.	WHAT TO DO	ACTION	RESULT
1	Remove the exhaust filter	<ul style="list-style-type: none">Remove the filter cover (Figure 11:4) van from the vacuum pump (Figure 11:1)Remove the leaf spring (Figure 11:3)Remove the old filter (Figure 11:2)	
2	Install the new filter	<ul style="list-style-type: none">Place the new filter in the openingMake sure the O-ring is properly placed on the filter inletInstall the leaf springInstall the filter cover	

6.6. Replacing the sealing wire



EXPLANATION

- Depending on your machine specification you can have one of the following (combinations of) seal elements:
 - Double seal: Two sealing wires
 - Cut-off seal: One sealing wire and one cutting wire
 - Wide sealing: One wide sealing wire
- The process of replacing of the seal elements is the same for all types
- Replace the sealing wires if the wire and/or the Teflon tape is damaged, or in accordance with the maintenance diagram

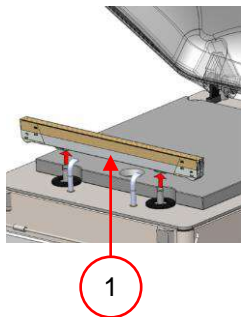

Figure 12: Removing the seal bar

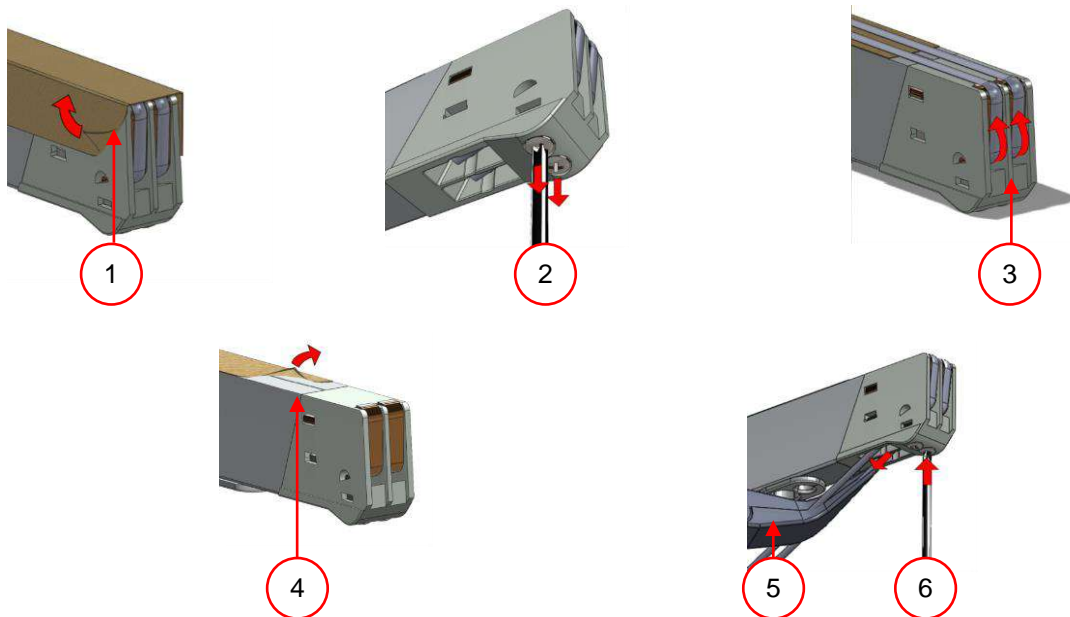

Figure 13: Replacing the sealing wire

NO.	WHAT TO DO	ACTION	RESULT
1	Remove the seal bar from his holders	<ul style="list-style-type: none"> Lift the sealing bar (Figure 12:1) from the cylinders 	
2	Remove the teflon tape	<ul style="list-style-type: none"> Remove the teflon tape (Figure 13:1) that protects the sealing wires 	
3	Remove the old sealing wires	<ul style="list-style-type: none"> Remove the screws (Figure 13:2) on the bottom side of the seal bar, and remove the sealing wires (Figure 13:3) 	
4	Replace the teflon tape on the sealing bar	<ul style="list-style-type: none"> Pull the teflon tape from the top of the sealing bar (Figure 13:4) Clean the bar with a lint-free cloth Put a new piece of Teflon tape of the same length on the sealing bar 	
5	Replace the sealing wires	<ul style="list-style-type: none"> Cut a new piece of sealing wire or cutting wire at the length of the seal bar plus about 15 cm (6 inches) First place the wire on one side of the seal bar by tightening the screws (Figure 13:2) Place the other end of the wire in a straight line and tighten with pliers. Then fasten it by tightening the screws Trim the ends of the wire on both sides 	
6	Replace the teflon tape on the sealing wire	<ul style="list-style-type: none"> Cut a piece of teflon tape at the length of the seal bar plus about 5 cm (2 inches) Stick the tape smoothly and without folds over the sealing wires on the sealing bar 	
7	Place seal bar	<ul style="list-style-type: none"> Place back the seal bar 	

6.7. Replacing the silicone rubber on the silicone holders



EXPLANATION

- In order to obtain a seal of good quality, the rubber should not be damaged and the surface must be flat
- Damage may be caused by burning with the seal wire or mechanical contact
- Replace the silicone rubber if it is damaged, or in accordance with the maintenance diagram in chapter 6.1

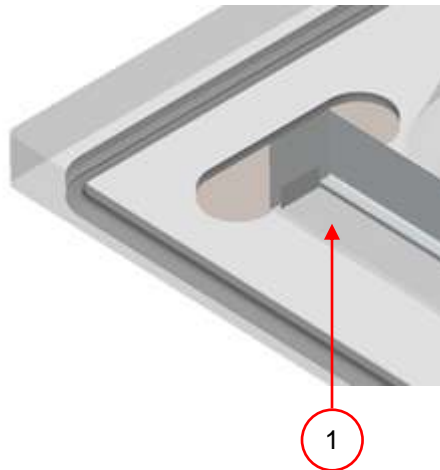

Figure 14: Replacing the silicone rubber of the silicone holders

NO.	WHAT TO DO	ACTION	RESULT
1	Remove the old silicone rubber	<ul style="list-style-type: none"> • You can pull the old silicone rubber (Figure 14:1) from the holder 	
2	Cut the new silicone rubber	<ul style="list-style-type: none"> • Cut a new piece of rubber. Make sure that it is just as long as the holder • The size is very important, it will cause problems with the seal of the bag if the rubber is too short or too long 	
3	Place the new silicone rubber	<ul style="list-style-type: none"> • Place the new piece in the silicone holder by pushing it into the recess • Ensure that the silicone rubber is fully and uniformly placed in the slot. It is also important that the surface of the silicone rubber is smooth after it is in place and that it shows no signs of stress 	

6.8. Replacing the lid gasket



EXPLANATION

- The lid gasket ensures that the vacuum chamber is completely closed off during the machine cycle. This is essential for the achievement of a maximum vacuum level. The lid gasket will wear out due to extreme pressure differences and should be changed regularly
- Replace the lid gasket if it is damaged or in accordance with the maintenance schedule in section 6.1



Figure 15: Replacing the lid gasket

NO.	WHAT TO DO	ACTION	RESULT
1	Remove the old gasket	<ul style="list-style-type: none"> • You can pull the old lid gasket off 	
2	Cut a new piece of gasket	<ul style="list-style-type: none"> • Cut a new piece of gasket. Cut it preferably slightly longer than the old one • The ends must be cut off straight • When the lid gasket is too short or too long, it can cause problems when closing the cover or leakage may occur 	
3	Place the new rubber	<ul style="list-style-type: none"> • Place the new lid gasket by pressing it in the slot. The lip of the gasket must face downwards and outwards • The gasket should be placed in the holder evenly and without tension. The ends must come tightly together to prevent leakage 	

7. TROUBLESHOOTING

The tables below show the possible interference with the corresponding cause and action to be taken

MALFUNCTION	ACTIVITY	SECTION
Control panel does not illuminate	<ul style="list-style-type: none"> Connect the machine to the power supply 	2.4
The control panel is on but there is no activity after closing the lid	<ul style="list-style-type: none"> Check / adjust the micro switch of the lid 	Please contact your supplier
Insufficient final vacuum	<ul style="list-style-type: none"> Check the vacuum settings of the program and adjust them 	5.5
	<ul style="list-style-type: none"> Make sure that the extraction opening is not covered 	
	<ul style="list-style-type: none"> Check the oil level in the pump 	2.3
	<ul style="list-style-type: none"> Check / replace the exhaust filter 	6.5
	<ul style="list-style-type: none"> Check / replace the lid gasket 	6.8
Vacuum process is slow	<ul style="list-style-type: none"> Make sure that the extraction opening is not covered 	
	<ul style="list-style-type: none"> Check the oil level in the pump 	2.3
	<ul style="list-style-type: none"> Check/ replace the exhaust filter 	6.5
Vacuum bag is not sealed correctly	<ul style="list-style-type: none"> Check the seal program settings and adjust them 	5.5
	<ul style="list-style-type: none"> Check / replace the Teflon tape and sealing wires 	6.6
	<ul style="list-style-type: none"> Check / replace silicones in the silicon holders 	6.7
	<ul style="list-style-type: none"> Check the inside of the vacuum for contamination and clean it 	
The lid does not open automatically	<ul style="list-style-type: none"> Check the gas springs 	Please contact your supplier
Error messages for SPDC		
F1 in display	<ul style="list-style-type: none"> Check / adjust the micro switch of the lid Make sure that the pump is running correctly 	Please contact your supplier
--- in display	<ul style="list-style-type: none"> Check if the lid is opened correctly 	

8. WARRANTY CONDITIONS

- This manual has been compiled with care. However Henkelman BV accepts no liability for any errors in this manual and/or for the consequences of an erroneous interpretation of the instructions.
- Henkelman BV accepts no liability for damage and/or problems arising from the use of spare parts not supplied by Henkelman BV.
- Henkelman BV reserves the right to change specifications and/or spare parts without prior notice.

8.1. Liability

1. We disclaim any liability to the extent that it is not required by law.
2. Our liability is limited to the total monetary amount of the value of the related machine.
3. With the exception of the applicable statutory provisions on public policy and good faith we are not obliged to pay to the counterparty or to third parties, any damages of any nature whatsoever, direct or indirect, including loss of profit, damage to movable or other property or personal injury.
4. We are in no way responsible for damages resulting from or caused by the use of the product used, or the unsuitability thereof for the purpose for which the other party decided to purchase.

8.2. Warranty

The warranty is subject to the following limitations. The warranty period for products supplied by Henkelman is 3 years from the date of the purchase document. This warranty is limited to manufacturing and machine errors, and therefore does not cover malfunctions due to a component of the product that has been exposed to any type of wear. Normal wear and tear as expected with the use of this product is therefore hereby excluded..

1. The responsibility of Henkelman is limited to the replacement of defective parts, we recognize no claims for any other form of damages or costs.
2. The warranty expires automatically in case of arrears or poor maintenance.
3. If there are doubts about maintenance or if the machine is not working properly, contact should always be made with the supplier.
4. The warranty does not apply if the defect is the result of improper or negligent use, or maintenance that is carried out in breach of the instructions mentioned in this manual.
5. The warranty is void if repairs or modifications on the product are carried out by third parties.
6. Defects arising from damage or injury caused by external factors are excluded from the warranty.
7. If we replace parts in accordance with the requirements of this warranty, the replaced components become our property.

The provisions relating to warranty and liability are part of the general terms that can be sent on request.

9. DISPOSE AS WASTE

Do not dispose oil and components with the household waste. Ensure that at the replacement of parts or oil after the lifecycle, that all materials are collected and destroyed or recycled in a legal and environmentally friendly manner.



Henkelman BV
Titaniumlaan 10
5221 CK, 's Hertogenbosch
The Netherlands

☎: +31-(0)73 621 3671
📠: +31-(0)73-622 1318

Email: info@henkelman.com
Website: www.henkelman.com