



Project:

Item:

Quantity:

VACUUM PACKING MACHINE BOXER 35 - SPEC SHEET

COMBIVAC BOXER 35
VACUUM PACKAGING MACHINE



FEATURES

- Seal bar length: 13.5"
- Seal bar with two wires, for double security
- Seal bar easily removable for cleaning and maintenance purposes
- Pump capacity: 678 cf/h (19 m³/h) Busch vacuum pump
- Pump maintenance and cleaning program
- Machine cycle: 15-30 sec
- **Standard Advanced Control System (ACS)**, with Sensor control: max. 99.8%, for an optimum and consistent vacuum and cycle time.
- Soft Air to protect the product and vacuum pouch
- 20 program memory (ACS)
- Transparent lid, which opens automatically after every cycle
- Deep drawn vacuum chamber
- Comes with insert plates for a faster cycle and product adjustment
- Stainless steel exterior
- 6ft cord with Nema 5-15P plug

DESCRIPTION

The robust, stainless steel Boxer 35 vacuum packer is standard equipped with a Busch vacuum pump. This Combivac machine is ETL listed and complies with UL, CSA and CE standards.

OPTIONS AND ACCESSORIES

- Cut-off seal (\$0)
- Wide seal (\$0)
- Inclined insert plate
- Food container adaptor
- Cart with castors and shelve
- Liquid control



WARRANTY

Henkelman Inc offers a warranty of 1 year on labor and 3 years on parts. For full warranty details, please refer to www.henkelman.com.

DATE

APPROVAL



FIT FOR FOOD SERVICE
WWW.HENKELMAN.COM

HENKELMAN INC.
 493 W Fullerton Ave
 Elmhurst IL, 60126

Sales and technical support
 P +1 331 979 2013
 F +1 630 359 3875
 E info@henkelmanusa.com
Service and warranty
 P +1 844 208 5685

VACUUM PACKING MACHINE BOXER 35 – SPECS

VACUUM PACKING MACHINE BOXER 35 – SPEC SHEET

DIMENSIONS

In inches

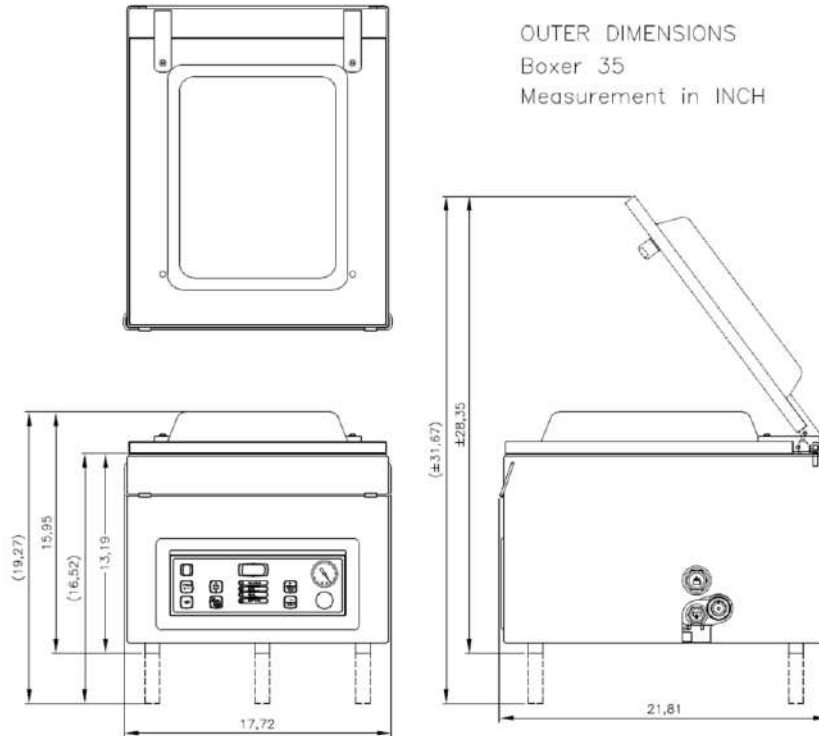

Model	Dimensions (inches)		Volts	Amps	Hz	Pump capacity	HP	Plug	Weight (lbs)
	Chamber (usable space) LxWxH	Machine LxWxH							
Boxer 35 Combivac	14.5"x13.5"x6"	21.8"x17.7"x15.9"	110-120V	9.5	60Hz	678 cf/h (19 m ³ /h)	0.74	NEMA 5-15P	115

NEMA 5-15P



15 A/125 V



FIT FOR FOOD SERVICE
WWW.HENKELMAN.COM

HENKELMAN INC.
493 W Fullerton Ave
Elmhurst IL, 60126

Sales and technical support
P +1 331 979 2013
F +1 630 359 3875
E info@henkelmanusa.com
Service and warranty
P +1 844 208 5685