

Prodigy™ Classic 6-10 (E/G)

Electric or Gas

UL

Engineered for dependability and cost savings, Prodigy™ Classic combination ovens are an all-in-one solution for efficient and consistent food production. These ovens do the work of a convection oven, kettle, steamer, fryer, and more. With labor-saving features, Prodigy Classic combination ovens are designed to support the most demanding kitchens.

ALTO-SHAAM



6-10 Classic

Standard features

- Boilerless steam generation
- Absolute Humidity Control™ for selecting any humidity level from 0-100% to maximize food quality, texture, and yield
- Three cooking modes—steam, convection, and combination
- 7" programmable, touchscreen control
- Easy recipe upload/download via USB port
- Five fully automated cleaning cycles
- Front-accessible and retractable rinse hose
- Zero clearance design
- EPA 202 compliant
- Temperature range: 85°F to 550°F (30°C to 302°C)



- 7** Seven full-size hotel or GN 1/1 pans
Six half-size sheet pans
- Two side racks with seven non-tilt support rails;
11-3/4" [298mm] horizontal width between rails,
2-3/8" [70mm] vertical spacing between rails
- 72 lb [33 kg] product maximum
45 quarts [57 liters] volume maximum

Copper Installation kits

Base kit selection on amp draw found in electrical table

Electric

- 20A [5026970]
- 30A [5026932]
- 40A [5026972]
- 50A [5026973]
- 80A [5026974]
- 125A [5026977]
- 175A [5026978]
- 200A [5026979]

Gas

- 20A [5026980]
- 30A [5026933]
- No cord [5026971]

CPVC Installation kits

Base kit selection on amp draw found in electrical table

Electric

- 20A [5021521]
- 30A [5021519]
- 40A [5021525]
- 50A [5021526]
- 80A [5021527]
- 125A [5021529]
- 150A [5021530]
- 200A [5021531]
- 250A [5021531]

Gas

- 20A [5021522]
- 30A [5021520]
- No cord [5021524]

Configuration for Gas Models (select one)

- Natural gas
- Propane

Electrical (select one)

- 120V 1ph (Gas only)
- 208–240V 3ph
- 440–480V 3ph

Door swing (select one)

- Right hinged
- Recessed door, optional (not available on ventless hood models)

Options

- Ventech™ Hood*
- Ventech™ PLUS Hood*

*Electric models only

Cleaning

- Automatic tablet-based cleaning system (standard)

Probe choices

- Probe package [5033743], includes receptacle and probe [PR-37158]
- Removable, single-point, sous vide probe [PR-36576] (optional)

Security devices for correctional facility use

- Optional base package (not available with recessed door); includes tamper-proof screw package
- Anti-entrapment device [5017157] (optional)
- Control panel security cover [5017145] (optional)
- Hasp door lock [padlock not included] [5017144] (optional)

Water treatment

- RO System OPS175CR/5 [5031203]
- Water filtration system [5037355]

Extended warranty

- One-year warranty extension

Installation options (select one)

- Alto-Shaam Factory Authorized Installation Program — available in the U.S. and Canada only
- Installation Start-Up Check — available through an Alto-Shaam authorized service agency

This equipment is UL listed for ventless operation. Ventless certification is for all food items, including foods classified as "fatty raw proteins." These foods include bone-in, skin-on chicken, raw hamburger meat, raw sausage, steaks, etc. Always consult local HVAC codes and authorities to ensure compliance with ventilation requirements. If you require further assistance, or local authorities and/or jurisdictions reject your request, please contact our dedicated Regulatory Compliance team.

[Accessories \(reference accessory catalog\)](#)



COA# 5760
Electric models only

Prodigi™ Classic 6-10 (E/G)



DIMENSIONS — standard door

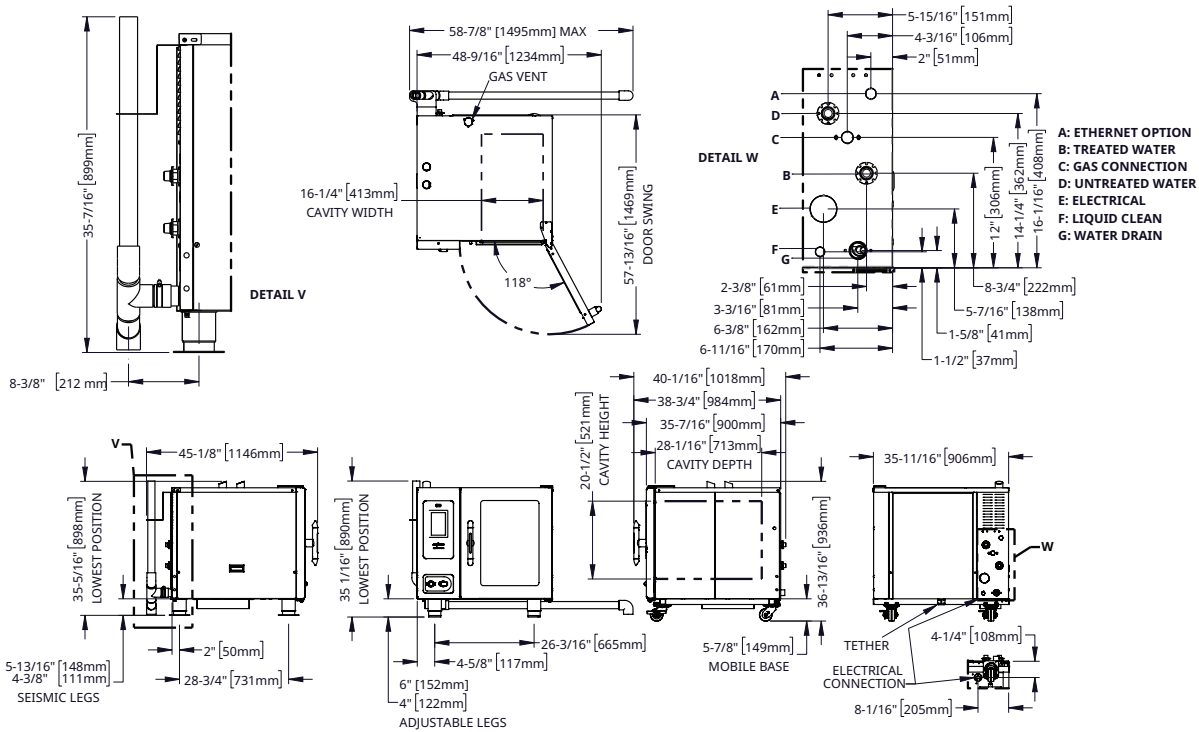

Model	Exterior (H x W x D)	Interior (H x W x D)	Net Weight
6-10	35-1/16" x 35-11/16" x 40-1/16" [890mm x 906mm x 1018mm]	20-1/2" x 16-1/4" x 28-1/16" [521mm x 413mm x 713mm]	Elec: 369 lb [167 kg] Gas: 418 [190 kg]

Ship Dimensions (L x W x H)*
56" x 45" x 51" [1422mm x 1143mm x 1295mm]

Ship Weight*
Elec: 508 lb [230 kg] Gas: 557 lb [253 kg]

*Domestic ground shipping information. Contact factory for export weight and dimensions.

OVENS WITH VENTECH® HOOD

Electric only

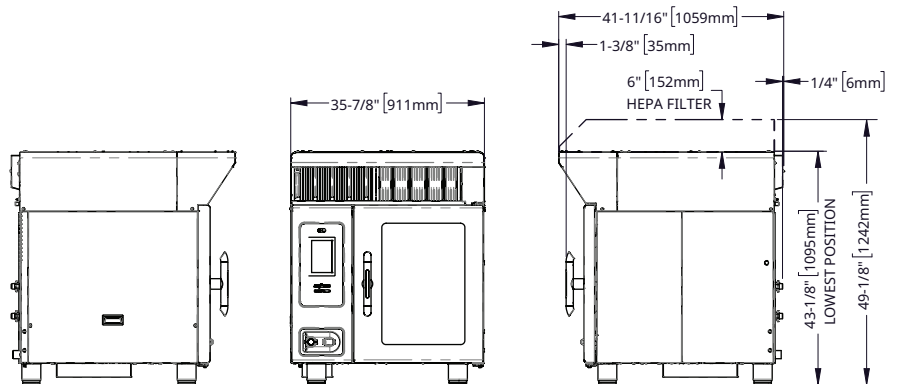

Model	Ventech Hood Exterior (H x W x D)	Net Weight	Ship Dimensions (L x W x H)*	Ship Weight*
VH-10	11-1/8" x 35-7/8" x 41-5/8" [282mm x 911mm x 1058mm]	121 lb [55 kg]	56" x 49" x 20" [1422mm x 1245mm x 508mm]	229 lb [104 kg]
	Ventech Hood Plus Exterior (H x W x D)	Net Weight	Ship Dimensions (L x W x H)*	Ship Weight*
	17-1/8" x 35-7/8" x 41-5/8" [435mm x 911mm x 1058mm]	174 lb [79 kg]	59" x 49" x 20" [1500mm x 1245mm x 508mm]	289 lb [131 kg]
	Oven with Ventech Hood (H x W x D)	Net Weight	Ship Dimensions (L x W x H)*	Ship Weight*
	43-1/8" x 35-7/8" x 41-11/16" [1095mm x 911mm x 1059mm]	Call factory	56" x 45" x 65" [1422mm x 1143mm x 1651mm]	Call factory
	Oven with Ventech Hood Plus (H x W x D)	Net Weight	Ship Dimensions (L x W x H)*	Ship Weight*
	49-1/4" x 35-7/8" x 41-11/16" [1242mm x 911mm x 1059mm]	Call factory	56" x 45" x 65" [1422mm x 1143mm x 1651mm]	Call factory

*Domestic ground shipping information. Contact factory for export weight and dimensions.

Prodigi™ Classic 6-10 (E/G)



DIMENSIONS — recessed door

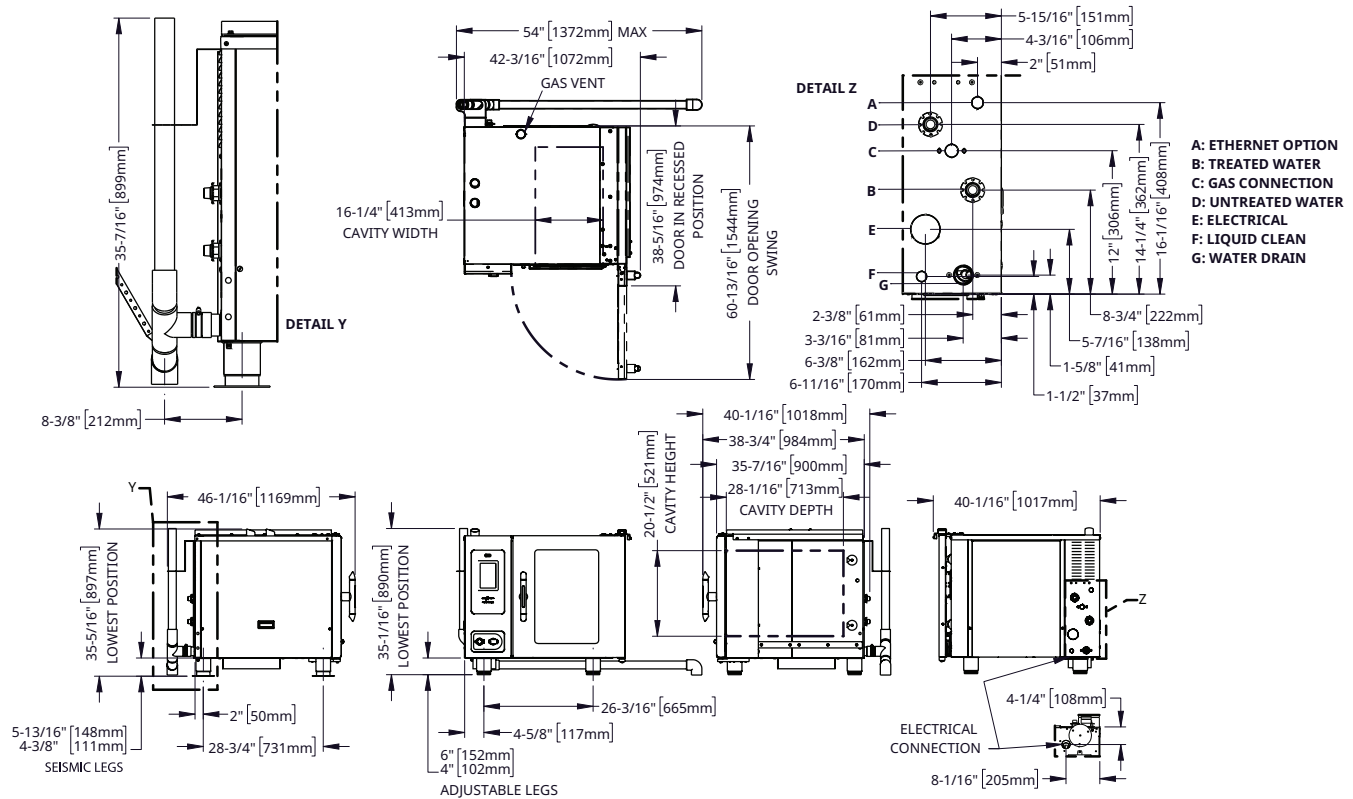

Model	Exterior (H x W x D)	Interior (H x W x D)	Net Weight
6-10	35-1/16" x 40-1/16" x 40-1/16" [890mm x 1017mm x 1018mm]	20-1/2" x 16-1/4" x 28-1/16" [521mm x 413mm x 713mm]	Elec: 380 lb [172 kg] Gas: 395 [180 kg]

Ship Dimensions (L x W x H)*
56" x 45" x 51" [1422mm x 1143mm x 1295mm]

Ship Weight*
Elec: 557 lb [253 kg] Gas: 557 lb [253 kg]

*Domestic ground shipping information. Contact factory for export weight and dimensions.

OVENS WITH VENTECH® HOOD

Electric only

Eliminate the need for a traditional kitchen hood. Ventech Type 1 hoods with condensation technology condense steam while capturing and removing grease-laden air, vapors, and lingering smoke. For more demanding locations, Ventech PLUS™ hoods include a HEPA filter. These hoods combine the fine particulate filtering of a HEPA filter with condensation technology of the standard Ventech hood.



Prodigi™ Classic 6-10 (E/G)



6-10E ELECTRIC

6-10E	V	Ph	Hz	AWG**	Standard Power					Connection
					A	A [^]	Breaker minimum	kW	kW [^]	
208–240V	208	3	50/60	10	21.9	22.6	28/29 [^]	7.9	8.14	3Ø/PE
	240	3	50/60	10	25.3	26.3	32/33 [^]	10.5	10.9	3Ø/PE
440–480V	440	3	50/60	14	11.6	12.2	15/16 [^]	9.1	9.3	3Ø/PE
	480	3	50/60	14	12.6	13.1	16/17 [^]	10.5	10.9	3Ø/PE

[^]Values for units with Ventech Hoods.

** Recommended minimum conductor sized at 90°C and ambient 30°C.

- Electrical connections must meet all applicable federal, state, and local codes.
- For use on individual branch circuit only.
- Ovens are not supplied with an electrical cord or plug.
- Electric supply may be hard-wired or use a cord and plug. Local codes may require a current protection device. If so, the device must accommodate a leakage current of 20mA.



6-10G ELECTRIC

6-10G	V	Ph	Hz	AWG**	Standard Power			Connection
					A	Breaker minimum	kW	
120V	120	1	60	12	6.8	20	0.84	1Ø/PE
208–240V	208	3	50/60	14	4.8	15	1.0	3Ø/PE
	240	3	50/60	14	4.2	15	1.0	3Ø/PE

** Recommended minimum conductor sized at 90°C and ambient 30°C.

- Electrical connections must meet all applicable federal, state, and local codes.
- For use on individual branch circuit only.
- Ovens are not supplied with an electrical cord or plug.
- Electric supply must be hard-wired. Local codes may require a current protection device. If so, the device must accommodate a leakage current of 20mA.

Prodigi™ Classic 6-10 (E/G)



CLEARANCE

- Top: 20" [508mm]
- Left: 0" [0mm]
- 18" [457mm] recommended service access
- Right: 0" [0mm] non-combustible surfaces
- 2" [51mm] combustible surfaces
- Bottom: 5-1/8" [130mm]
- Back: 4" [102mm] between plumbing and nearest object



RESTRICTIONS

- Oven must be installed level.
- Oven must be installed on noncombustible surface.
- Use a water supply shut-off valve and back-flow preventer when required by local code.
- Drain must not be located directly underneath the appliance unless a stand with solid top or shelf is used.
- Exhaust hood installation is required on gas-heated models.



HEAT: ELECTRIC

Heat of rejection

6-10E	Heat Gain qs, BTU/hr	Heat Gain qs, kW
	630	0.18



NOISE: ELECTRIC

Noise emissions

Without hood system, a maximum 67 dBA was measured at 3.3 ft [1 m] from unit.

With hood system, a maximum 73 dBA was measured at 3.3 ft [1 m] from unit.



HEAT: GAS

Heat of rejection

6-10G	Heat Gain qs, BTU/hr	Heat Gain qs, kW
	269	0.08



NOISE: GAS

Noise emissions

Without hood system, a maximum 67 dBA was measured at 3.3 ft [1 m] from unit.



GAS REQUIREMENTS

- Gas Requirements
- Gas type must be specified on order
 - Hook-up: 3/4" NPT

UL Marked Appliances	Maximum Input BTU/h	Maximum Inlet Pressure Inches WC (kPa)	Minimum Inlet Pressure Inches WC (kPa)	Maximum Fuel Consumption*	
				CFH	GPH
Natural Gas	43,000	14.0 [3.5]	5.5 [1.1]	45.7	N/A
Propane	43,000	14.0 [3.5]	9.0 [2.8]	19.2	0.5

*Assumes an average heating value for natural gas to be 1050 BTU/SCF and a specific gravity of 0.60. The assumed value for propane gas is 2,500 BTU/SCF, and a specific gravity of 1.53.



WATER

Water requirements (per oven)

Two cold water inlets — drinking quality

- One treated water inlet: 3/4" NPT male connection. Line pressure 30 psi minimum dynamic and 90 psi maximum static [200–1000 kPa] at a minimum flow rate of 0.26 gpm [1 L/min].
- One untreated water inlet: 3/4" NPT male connection. Line pressure 30 psi minimum dynamic and 90 psi maximum static [200–1000 kPa] at a minimum flow rate of 2.64 gpm [10 L/min]. Water drain: 1-1/2" [40mm] connection with a vertical vent to extend above the exhaust vent. Materials must withstand temperatures up to 200°F [93°C].

Water Quality Standards

It is the sole responsibility of the owner/operator/purchaser of this equipment to verify that the incoming water supply is comprehensively tested and, if required, a means of "water treatment" provided that would meet compliance requirements with the published water quality standards shown below. Non-compliance with these minimum standards will potentially damage this equipment and/or components and void the original equipment manufacturer's warranty. Alto-Shaam recommends using the Alto-Shaam Reverse Osmosis System or a water filtration system to properly treat your water.

Inlet Water Requirements		
Contaminant	Treated Water	Untreated Water
Free Chlorine	Less than 0.1 ppm [mg/L]	Less than 0.1 ppm [mg/L]
Hardness	30-70 ppm	30-70 ppm
Chloride	Less than 30 ppm [mg/L]	Less than 30 ppm [mg/L]
pH	7.0 to 8.5	7.0 to 8.5
Silica	Less than 12 ppm [mg/L]	Less than 12 ppm [mg/L]
Total Dissolved Solids [tds]	50-125 ppm	50-360 ppm



CLEARANCE

Clearance requirements for water filtration system

Do not install a water filtration system behind unit.

CONTACT US

W164 N9221 Water Street | Menomonee Falls, Wisconsin 53051 | U.S.A.
 Phone: 262.251.3800 | 800.558.8744 U.S.A./Canada | Fax: 262.251.7067 | alto-shaam.com