

Item # _____

Qty # _____

Model # _____

Project # _____



DUKERS

Quality Commercial Refrigeration







GAS RANGE

DCR36-6B / 6 Burner Gas Range



PRODUCT DESCRIPTION

-  Stainless steel exterior including front, back sides, kick plate, back guard and over shelf
-  Heavy duty 12" X 12" removable, cast iron top grates
-  Oven temperature range between 175°F to 500°F
-  3/4" NPT rear gas connection and regulator standard.
-  Two(2) chrome oven rack per oven standard, multiple position oven rack guides
-  Enamel interior oven for easy cleaning.
-  6" casters with lock for easy mobility.



HIGH QUALITY STAINLESS STEEL & ROBUST DESIGN

GAS RANGE MODEL	DIMENSION		
	Width	Depth	Height
DCR36-6B	36 in	31 1/2 in	56 in



Los Angeles | San Francisco | Dallas
Houston | Florida | Chicago | New Jersey

1-800-931-8628

@ info@dukersusa.com

www.DukersUSA.com

DETAILS & SPECIFICATIONS

DCR36-6B

Front View

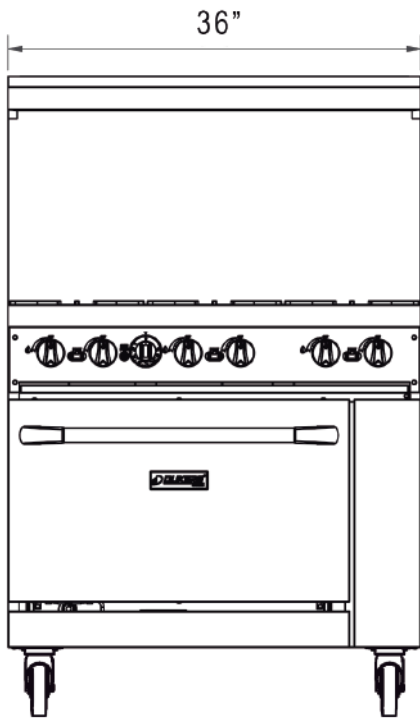

Side View

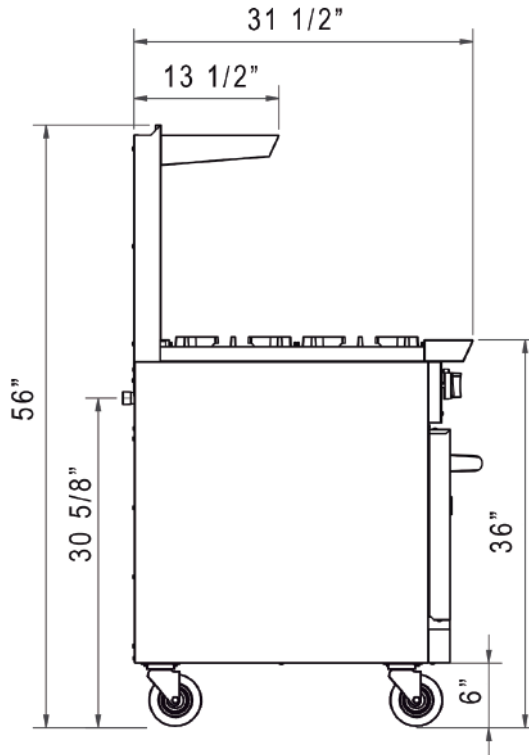

Top View

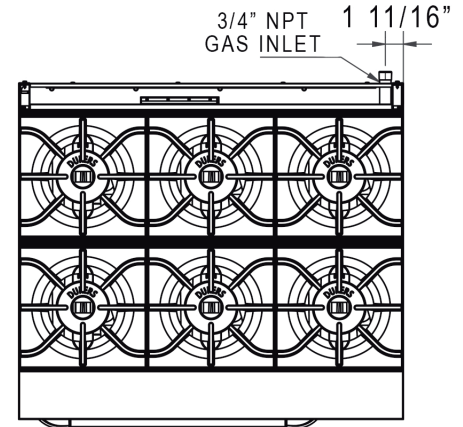



 SANITATION C US
 Conforms to NSF/ANSI7 (ETL)

 PROUD MEMBER
CFESA
 Commercial Food Equipment Service Association

Product Specifications

WORKING AREA 36" x 24"
 GAS TYPE LPG/NG

BURNERS
 SINGLE OUTPUT BTU
 NOZZLE #
 TOTAL OUTPUT BTU
 GAS PRESSURE

LPG		NG	
HOT PLATE	OVEN	HOT PLATE	OVEN
6	1	6	1
30000 BTU	35000 BTU	33000 BTU	35000 BTU
52	49	41	38
215000 BTU		233000 BTU	
10		5	

Model	Packaging Dimensions (inches)			Net Weight (lbs)	Ship Weight (lbs)	Container Capacity 40'HQ
	W	D	H			
DCR36-6B	38 1/10"	36 4/5"	38 1/5"	384.96	438.68	52



Los Angeles | San Francisco | Dallas
 Houston | Florida | Chicago | New Jersey

1-800-931-8628

info@dukersusa.com

www.DukersUSA.com