



9 Hampshire St., Mansfield, MA 02048
www.kinteraequipment.com

Project:	
Model #:	
Item #:	
Available W/H:	Qty:
Approval:	
AIA #:	SIS #:
CSI Section 11400	

Sandwich / Salad Unit

Food Prep Tables
KINTERA

Model : KS48



≡ FEATURES & BENEFITS ≡

■ **Hydrocarbon refrigerants (R-290)**

With innovative and eco-friendly technology, KINTERA brings you hydrocarbon refrigerators designed to meet DOE's Energy Conservation Standards in 2017 and to use EPA's SNAP Program approved HC refrigerants. Hydrocarbon refrigerants do not deplete the ozone layer and have very low contribution to global warming (ODP-0, GWP-3).

■ **Cold air compartment**

Our innovative "Cold Air Compartment" maintains temperature evenly for each pan to preserve fresh food longer. In addition, the compartment isolates pans from the reach-in area to prevent food spillage.

■ **Cabinet construction**

KINTERA model boasts a stainless steel exterior (door) with AL exterior sides (galvanized steel back and bottom). Interior is stainless steel floor and back with AL sides. It guarantees the utmost in cleanliness and long product life.

■ **High-density polyurethane insulation**

The entire cabinet structure and solid doors are foamed-in-place using high density, CFC free polyurethane insulation.

■ **Convenient cutting board side rail**

■ **Self-contained system**

■ **4" dia. swivel casters with locks on the front set**

■ **1/6 size, 4" deep condiment pans included**

■ **9-1/2" deep, 1/2" thick cutting board included**

■ **Adjustable, heavy duty, PE (polyethylene) coated wire shelves**

■ **Refrigerator holds 33°F ~ 39°F for the best in food preservation**



Model	Product ID	Swing Doors	CU./FT.	#of Shelves	#of Pans	#of Hood	HP	AMPS	Crated Weight (lbs.)	L x D* x H† (inches)
KS48	919705	2	16.26	2	12	1	1/3	3	269	48 1/4 x 30 x 37 1/2

Model : KS48

ELECTRICAL DATA	
Voltage	115/60/1
Plug Type	 NEMA 5-15P
Full Load Amperes	3
Compressor HP	1/3
Cord Length (ft.)	9
Refrigerant	R-290
DIMENSIONAL DATA	
Net Capacity (cu. ft.)	16.26
Ext. Length Overall (in.)	48 1/4 (1225mm)
Ext. Depth Overall (in.)*	30 (764mm)
Ext. Height Overall (in.)†	37 1/2 (952mm)
# of Doors	2
# of Shelves	2
Shelf Size (L x D) (in.)	21 x 17
Net Weight (lbs.)	249
Gross Weight (lbs.)	269

Design and specifications subject to change without notice.

Actual shipping weight may differ due to extra packing materials for product protection.

* Depth does not include 1-1/4" for rear spacers.

† Height does not include 4-3/4" for caster height.

- **WARRANTY : 2 Year Parts and Labor Warranty**
Additional 3 Year Warranty on Compressor

PLAN VIEW

(unit : inch)

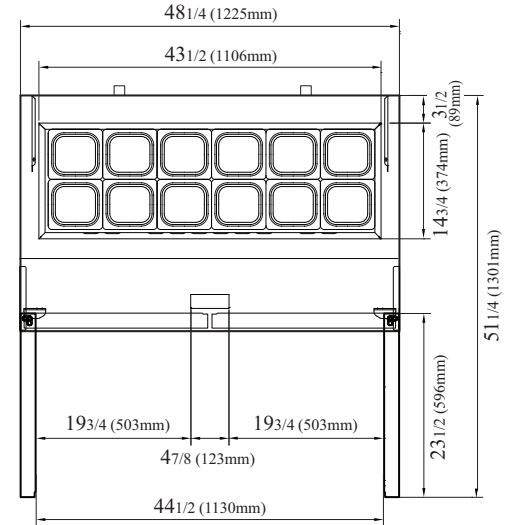

TOP VIEW

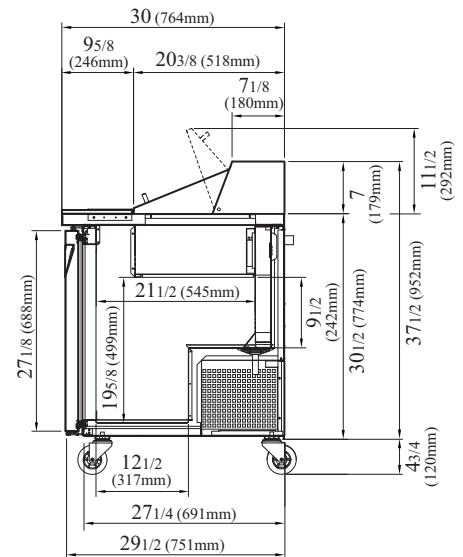

SIDE VIEW

Ver.20240514



Warranty : 800-381-7770
info@kinteraequipment.com