



# MAESTRO SERIES

MODULAR  
ICE MACHINE

## IM-0460-AC/AH-22

※ Replace WM-0460-AC/AH-22

### AIR COOLED

#### KEY FEATURES:

- Up to 443 lbs production capacity (70F/50F, 24 Hours)
- 304 stainless-steel exterior (durable & rust-resistant)
- Simple diagnostic panel to assist service & maintenance
- Cleaning switch for auto cleaning cycle
- Magnetic frame cleanable condenser air filters
- Adjustable flush time to reduce scale & cleaning cost
- ABS antimicrobial interior to reduce slime & cleaning cost
- Water distributor tube & water sump removal without tools
- Heavy duty water curtain, pins & hangers for easy removal
- Hinged front door panel for easy access
- No screws on side or back panels for easy access
- Sides & top vent for increased ventilation
- Improved evaporator section to reduce airborne bacteria
- Power cord with NEMA 5-15 plug

#### STANDARD WARRANTY:

- Ice Maker: 3-Year Parts & Labor
- Evaporator: 5-Year Parts & Labor
- Compressor: 5-Year Parts & 3-Year Labor

#### CERTIFICATIONS



IM-0460-AH-22 shown with IB-026-22

#### Recommended Ice Storage Bin:



IB-026-22 (265lbs) IB-033 (350lbs) / IB-044 (440lbs)

※ Bin top adapter needed to use IB-033/044 (30" Bins)  
IBT-2230R: 8" Bin top adapter to left mount 22" Head on IB-033/044  
IBT-2230B: 4" (2) Bin top adapters to center mount 22" Head on IB-033/044

#### Recommended Water Filtration:

IcePro 400 (replacement cartridge: IcePro 400R)



※ Extend Warranty Program when you install and register IcePro 400 water filtration with IM-0460-AC/AH-22.  
For more information, visit to [www.icetroamerica.com/registration](http://www.icetroamerica.com/registration).

# IM-0460-AC/AH-22

## MAESTRO SERIES (MODULAR ICE MACHINE)

### PLAN VIEW

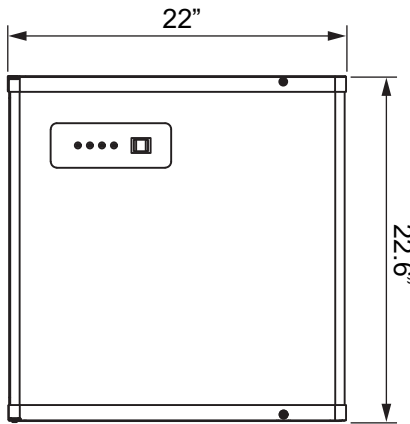

FRONT VIEW

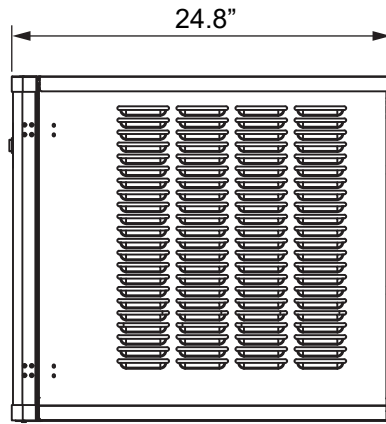

SIDE VIEW

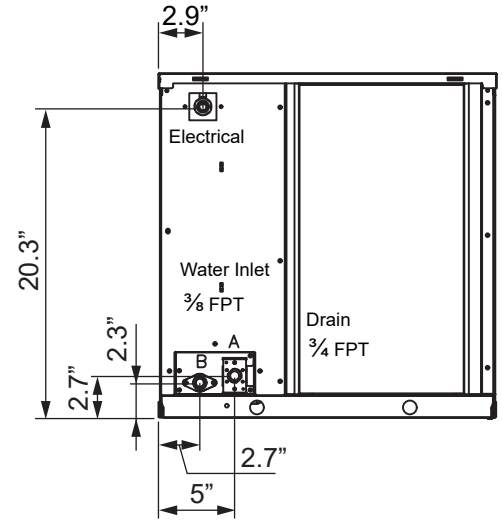

BACK VIEW

MODEL	DIMENSIONS	WIDTH	DEPTH	HEIGHT	WEIGHT	
IM-0460-AC/AH-22	Inch	22"	24.8"	22.6"	143.3 lbs (Net)	168 lbs (Shipping)

### SPECIFICATIONS

Model	Ice Shape	Ice Production per 24 hrs		Water usage Gal / 100 lbs ice	Power kWh / 100 lbs ice	Electrical (V/Hz/ph)	Condenser	Minimum Circuit Breaker (A)
		70 °F Air/ 50 °F Water	90 °F Air/ 70 °F Water					
<b>IM-0460-22</b>	AC: Cube AH: Half Cube	443 lbs	327 lbs	18.0	6.21	115 / 60 / 1	Air Cooled	15

OPERATING LIMITS	MIN	MAX
AMBIENT TEMP RANGE	50 °F	100 °F
WATER TEMP RANGE	50 °F	90 °F
WATER PRESSURE	20 psi (1.38 bar)	80 psi (5.52 bar)

### ICE SHAPE: Cube & Half Cube



Cube

$7/8" \times 7/8" \times 7/8"$



Half Cube

$1 1/8" \times 3/8" \times 7/8"$

\* Design and specifications are subject to change without prior notice.

If you love your Ice...  
It's time to love your Ice Machine!

