



INSTALLATION & OPERATION MANUAL

GAS CONVECTION OVENS

Models

DCCOG1

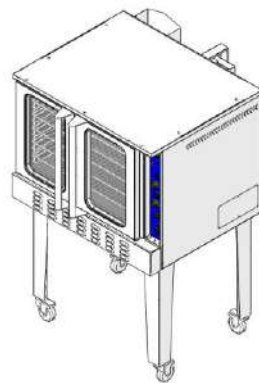

DCCOG2

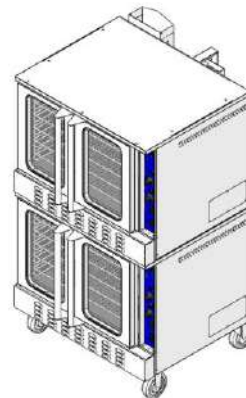

Please read and keep these instructions.

Indoor use only.

1-800-931-8628 | WARRANTY@DUKERSUSA.COM | WWW.DUKERSUSA.COM

-SAFETY PRECAUTIONS-

Before installing and operating this equipment, be sure everyone involved in it operation is fully trained and aware of precautions. Accidents and problem can be caused by failure to follow fundamental rules and precautions.

Contact the factory, the factory representative, or a local service company to perform maintenance and repairs.

The following symbol, found throughout this manual, alert you to potentially dangerous conditions to the operator, service personnel, or to the equipment.

 **DANGER**

This symbol warns of immediate hazards that will result in severe injury or death

 **WARNING**

This symbol refers to a potential hazard or unsafe practice that could result in injury or death

 **CAUTION**

This symbol refers to a potential hazard or unsafe practice that could result in injury, product damage, or property damage

 **NOTICE**

This symbol refers to information that needs special attention or must be fully understood, even though not dangerous

 **WARNING:** Improper installation, adjustment, alteration, service or maintenance can cause property damage, injury or death. Read the installation, operating and maintenance instructions thoroughly before installing or servicing this equipment.

WARNING**Electrical Grounding Instructions**

This appliance is equipped with a three-prong (grounding) plug for your protection against shock hazard and should be plugged directly into a properly grounded three-prong receptacle. Do not cut or remove the grounding prong from this plug.

⚠ NOTICE

This product is intended for commercial use only. NOT FOR HOUSEHOLD USE.

⚠ WARNING

Fire Hazard

Do not store or use gasoline or other flammable vapors and liquids in the vicinity of this or any other appliance.

Keep area around cooking appliances free and clear of combustibles. Purchaser of equipment must post in a prominent location detailed instructions to be followed in the event the operator smells gas. Obtain the instructions from the local gas supplier.

MINIMUM CLEARANCES

⚠ WARNING

	Minimum Clearance from Non-Combustible Construction	Minimum Clearance from heat producing appliance
Back	2"	6"
Right Side	2"	6"
Left Side	2"	6"
Floor	0"	NOT ALLOWED

Gas Pressure

The appliance and its individual shutoff valve (to be supplied by user) must be disconnected from the gas supply piping system during any pressure testing of that system at test pressures in excess of 1/2 PSI (3 .45 kPa).

The appliance must be isolated from the gas supply piping system by closing its individual manual shut-off valve during any pressure testing of the gas supply piping system at test pressures equal to or less than 1 / 2 PSI (3 .45 kPa).

The installation shall be made with a connector that complies with the Standard for Connectors for Movable Gas Appliances, ANSI Z21.69 • CSA 6.16, and a quick-disconnect device that complies with the Standard for Quick-Disconnect Devices for Use With Gas Fuel, ANSI Z21.41 • CSA 6.9.

All pipe joints and connections must be tested thoroughly for gas leaks. Use only soapy water for testing on all gases.

NEVER use an open flame to check for gas leaks. All connections must be checked for leaks after the unit has been put into operation. Test pressure should not exceed 14” W.C.

Model	Total BTU	# of Oven	Gas Type	Orifice Size
DCCOG1	54,000	1	NG	47
			Propane	55
DCCOG2	54,000+54,000	1+1	NG	47
			Propane	55

The gas type used in the appliance is equipped at factory. Please refer to the rating plate which fixed to the right side of appliance.

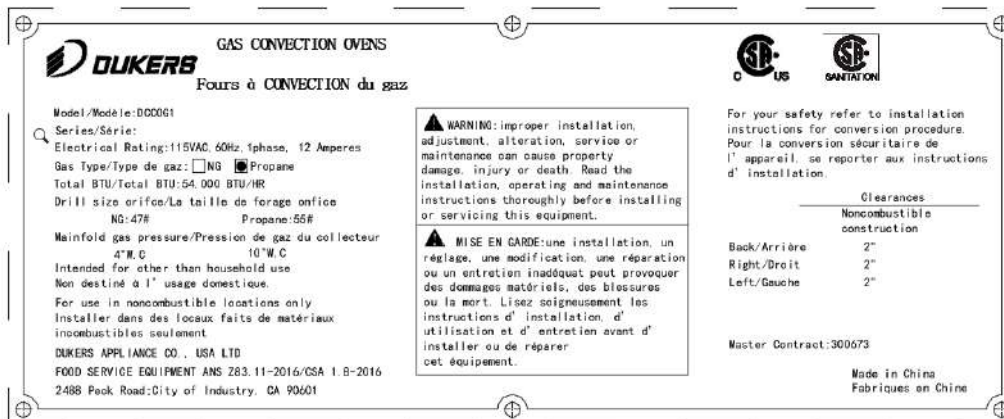

If you want to change the using gas type, please see the conversion

instruction**ELECTRICAL SUPPLY**

The appliance, when installed, must be electrically grounded in accordance with local codes, or in the absence of local codes, with the National Electrical Code, NFPA 70, or the Canadian Electrical Code, CSA C22.2

Model	Power Type	# of Oven	Maximum Amps
DCCOG1	120 Volts, 60 Hz, 1 Phase	1	12
DCCOG2	2@120 Volts, 60 Hz, 1 Phase	1+1	12+12

Ovens ordered with the 120V power option are equipped with one or two power cords with a standard 120V single-phase plug with a ground prong. Single-deck ovens will have one power cord; double-deck ovens will have two.

INSTALLATION

The installation must conform with local codes, or in the absence of local codes, with the National Fuel Gas Code, ANSI Z223.1/NFPA 54, or the Natural Gas and Propane Installation Code, CSA B149.1, including:

- i) The appliance and its individual shutoff valve must be disconnected from the gas supply piping system during any pressure testing of that system at test pressures in excess of 1/2 psi (3.5 kPa).
- ii) The appliance must be isolated from the gas supply piping system by closing its individual manual shutoff valve during any pressure testing of the gas supply piping system at test pressures equal to or less than 1/2 psi (3.5 kPa).

The appliance, when installed, must be electrically grounded in accordance with local codes, or in the absence of local codes, with the National Electrical Code, NFPA 70, or the Canadian Electrical Code, CSA C22.2

The installation shall be made with a connector that complies with the Standard for Connectors for Movable Gas Appliances, ANSI Z21.69 • CSA 6.16, and a quick-disconnect device that complies with the Standard for Quick-Disconnect Devices for Use With Gas Fuel, ANSI Z21.41 • CSA 6.9.

UNPACKING

1. Remove packaging before beginning installation ;
For double-deck-ovens (DCOG2) already completely assembled at the factory.
2. If you are installing a single-deck oven (DCOG1), follow these steps:
 - (1) Raise oven sufficiently to allow clearance for the legs to be attached. Use of a lift truck or other mechanical lifting means is recommended. For safety, “shore up” and support the oven with an adequate blocking arrangement strong enough to support the load. (If it is absolutely necessary to rest the oven on its side, rest it on its left side or back side. Take care to protect the finish on the left side, and to prevent the weight from resting on the motor on the back.)
 - (2) Attach the legs to the bottom corners of the oven using the provided machine screws, flat washers, and lock washers. Each leg is secured by five screws. The mounting holes are pre-drilled and threaded.
 - (3) Screw into the bottom of each leg a caster. The two casters with brakes should be attached to the front legs.
 - (4) Lower the oven gently onto a level surface. Never drop or allow the oven to fall.
 - (5) Use a level to make sure that the oven is level. The adjustable feet can be screwed in or out to lower or raise each corner of the oven.

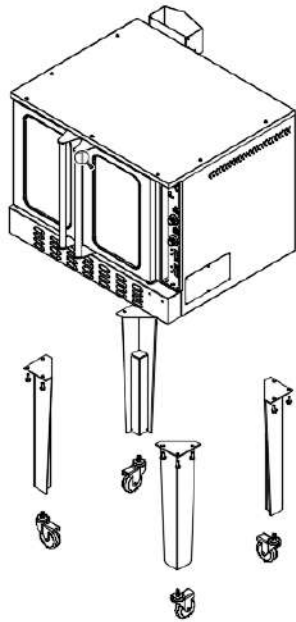

INSTALLATION OF RESTRAINT (ONLY FOR OVENS WITH CASTERS)

NOTICE

For an appliance equipped with casters, (1) the installation shall be made with a connector that complies with the Standard for Connectors for Movable Gas Appliances, ANSI Z21.69 or Connectors for Moveable Gas Appliances, CAN/CGA-6.16, and a quick-disconnect device that complies with the Standard for Quick-Disconnect Devices for Use With Gas Fuel, ANSI Z21.41, or Quick Disconnect Devices for Use with Gas Fuel, CAN1-6.9, (2) adequate means must be provided to limit the movement of the appliance without depending on the connector and the quick disconnect device or its associated piping to limit the appliance movement and (3) the restraining means should be attached to a frame member on the back of the unit.

WARNING

Please be aware there is a restraint on the appliance and, if disconnection of the restraint is necessary, to reconnect this restraint after the appliance has been returned to its originally installed position.

To avoid accidental gas disconnection and potential explosion, when installing the product, connect the wall to the product with a chain of sufficient strength, the length of the chain should not be greater than 80% of the length of the hose, as shown in the figure below

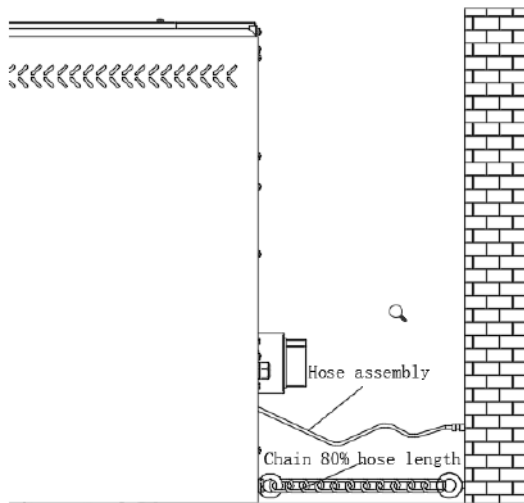

CONNECT GAS SUPPLY

1. The serial plate is located on the side panel. It indicates the type of gas the unit is equipped to use. All equipment is set for use with the specified gas type at the factory.
2. The equipment is design-certified for operation on either natural or propane gas; it should only be connected to the type of gas for which it is equipped as stated on the serial plate.
3. A 3/4" NPT inlet is located at the rear for the gas connection. The external regulator provided with the unit must be installed. An adequate gas supply is imperative. Undersized or low-pressure lines will restrict the volume of gas required for satisfactory performance.
4. An adequate gas supply line to the unit should be no smaller than 3/4" diameter.
5. Ensure the supply line is clean before connecting the line to the unit.
6. All pipe joints and connections must be tested thoroughly for gas leaks. Use only soapy water for testing on all gases. Never use an open flame to check for gas leaks.

CONNECT ELECTRICITY SUPPLY

1. Before connecting your appliance, ensure your units voltage is compatible with your plug type.
2. Electrical Grounding Instructions:
This equipment is equipped with a three-prong (grounding) plug for your protection against shock hazard and should be plugged directly into a properly grounded three prong receptacles. Do not cut or remove the grounding prong from this plug.

Exhaust System

 **WARNING****Not obstruct the flow of combustion and ventilation air**

1. This unit must be installed in accordance with all applicable hood regulations.
2. This unit is not designed to be directly connected to an evacuation duct for the discharge of combustible products.
3. The room where the equipment is installed must be fitted with air intakes to guarantee the correct operation of the unit and air exchange.
4. During installation, make sure the air suction and evacuation ways are free from any obstacles.

Electrical Diagram

The WIRING DIAGRAM is located on behind the control panel;

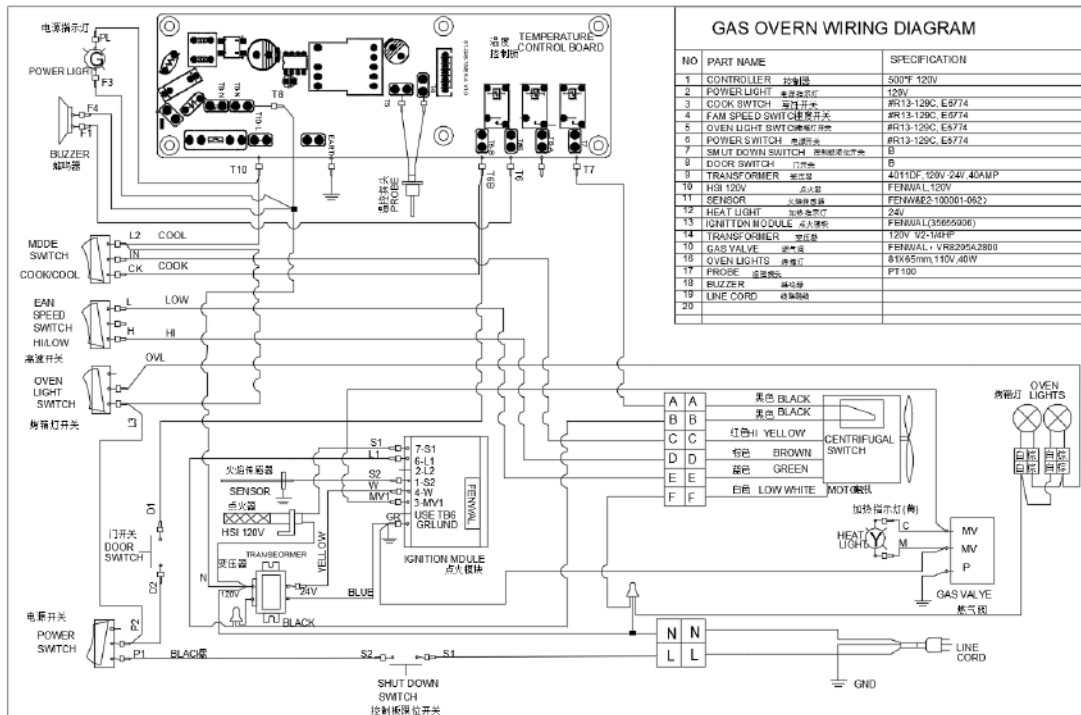
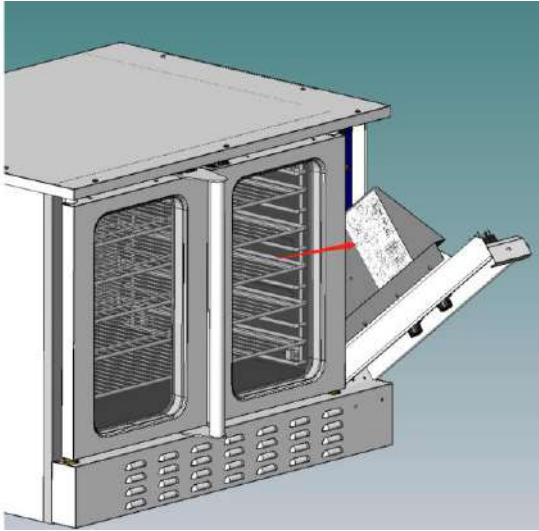

Operating Instructions

DANGER

EXPLOSION HAZARD

In the event a gas odor is detected, shut down equipment at the main shut off valve. Immediately call the emergency phone number of your gas supplier.

CAUTION

To eliminate gas build up which could result in an explosion, in the event of main burner ignition failure a five minute purge period must be observed prior to re-establishing ignition source.

Lighting, Relighting, and Shutdown Instructions

1. To light the oven, flip the lamp switch at the control panel to the "ON" position. The oven is equipped with a direct hot surface ignition system. There is no pilot to light.
2. Turn the oven to the desired temperate. The burners should be automatically ignited with the hot surface ignition system. If the burners fail to ignite within 4 seconds, the oven will automatically shut off the gas. Wait 5 minutes to allow the gas that was released to dissipate, and try to light the burners again. If the burners still fail to ignite after 3 such attempts, the oven will stop trying, even though the power switch is in the "ON" position. To continue to attempt to light the burners, turn the power switch "OFF" and then "ON" again.
3. To shut down the oven, flip the power switch to the "OFF" position.

Operating The Controls

Control Panel

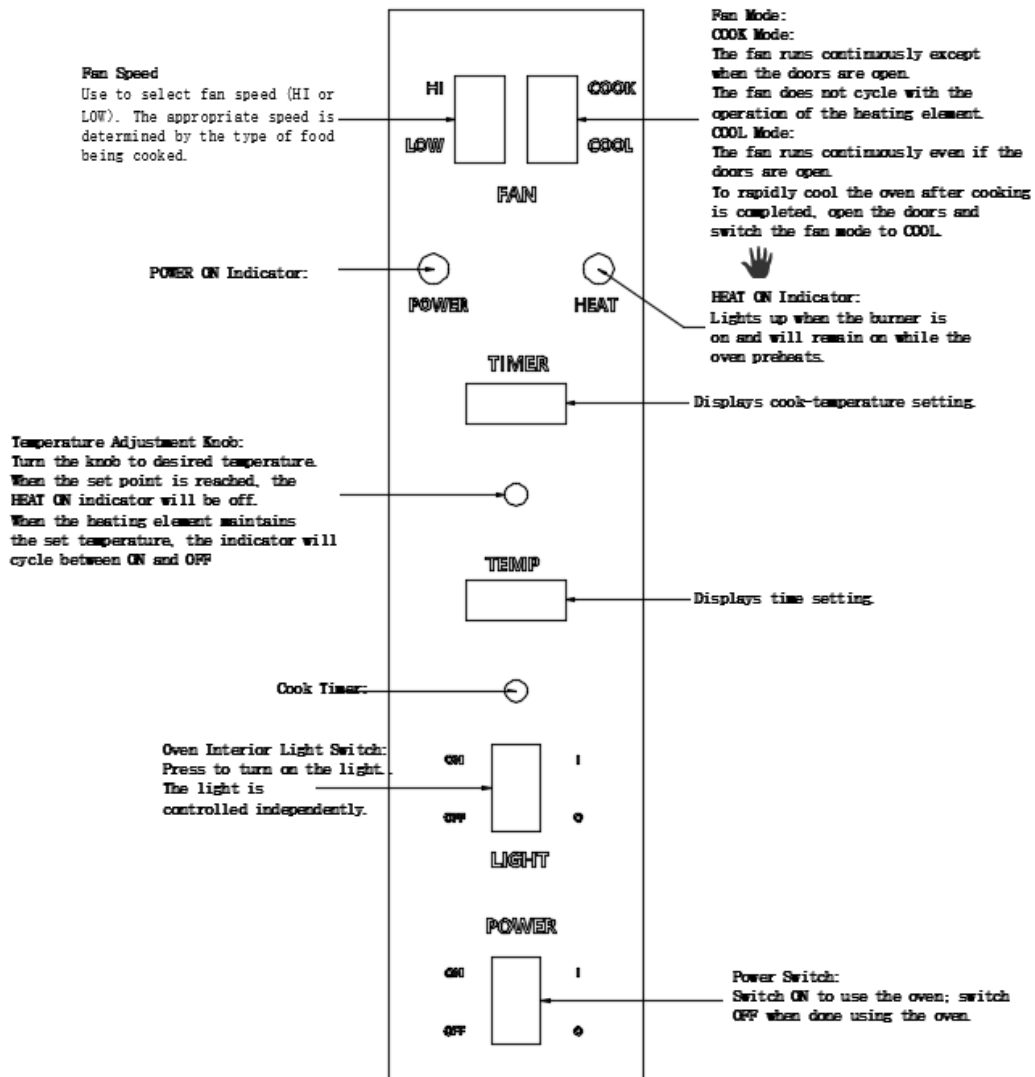

Cooking Instructions

To cook, do the following:

1. Turn the oven ON using the Power Switch at the bottom of the control panel.
2. Select the desired fan speed using the Fan Speed switch. The appropriate fan speed (HI or LOW) depends on the type of food being cooked.
3. Switch the Fan Mode switch to COOK. The fan will run continuously when the oven doors are closed (the fan does not cycle on and off with the burners). (If this switch is set to COOL the only difference is that the fan will continue to run when the oven doors are open.)
4. Set the cooking temperature by turning the Cook Temperature Control to the desired cooking temperature. The Heat On indicator will light when the burners are on, and will remain on while the oven preheats.
5. Wait until the Heat On indicator has come gone out. At that time the oven will have reached the set cooking temperature.
6. Open the oven doors, load the product into the oven, and close the doors.
7. Select the desired cooking time by turning the Cook Timer Control to the top of the time display window. The time setting will start counting down.
 - If you open the oven doors, the burners in cool mode will shut off until the doors are closed. However, the timer will continue running even if the doors are open.
8. When the load has finished cooking, you can rapidly cool the load by opening the oven doors (which will shut off the burners) and switching the Fan Mode to COOL (which will cause the fan to run even though the doors are open). For the most rapid cooling, also switch the Fan Speed switch to HI.
9. When you are done cooking, switch the Power Switch to OFF.

Operating Instructions

Warnings

1. Always ensure proper supervision while the equipment is in use.
 2. Simple adjustments to knobs, leg height, etc. do not require assistance from specialized personnel. For more technical adjustments, please consult a qualified technician.
 3. Use only parts and accessories recommended by Cooking Performance Group.
 4. During the initial uses of the equipment, an acrid or burning smell may be detected. This will disappear after two or three uses. Or set unit to 450-500°F for 30 min. or until smell starts to disappear, then turn unit off and let cool.
 5. The equipment will remain hot for a short time after use (residual heat). Avoid all physical contact with the unit during this time to prevent injury.
 6. This equipment is strictly for professional use and must be used by qualified personnel.
 7. The installation, startup, and maintenance of this equipment must be carried out by a qualified technician.
 8. All installation must be carried out according to the law. Cooking Performance Group is not responsible for damages due to an incorrect installation, improper maintenance, or incorrect use.
- These are very important regulations; if they are neglected, the equipment may not perform properly or the user may be placed at risk and void manufacturer warranty.

Cleaning & Maintenance

WARNING

FOR YOUR SAFETY, DISCONNECT THE POWER SUPPLY TO THE APPLIANCE BEFORE CLEANING.

WHEN CLEANING THE BLOWER WHEEL, BE SURE TO HAVE THE POWER SWITCH IN THE “OFF” POSITION.

1. Turn the power switch to OFF and allow the oven to cool.
2. Remove the oven-interior racks and rack slide frames. (The rack slide frames are readily removable by merely raising to disengage them from their sockets.) Wash the racks and rack slides in a sink with mild detergent and warm water. Dry them thoroughly with a clean cloth.
3. Look to see if any foreign matter has accumulated on the blades of the blower wheel (which will reduce air circulation). If necessary, remove the rear lining of the oven, which is secured by thumbscrews near each corner. Use a stiff brush to remove accumulations from the blower blades, then wash with soap and water.
4. Wash the interior surfaces with mild detergent and warm water. Rinse with clean water, and dry thoroughly with a clean cloth. For stubborn accumulations, a commercial oven cleaner may be used.
5. Clean the control panel with warm water and mild soap. Never use cleaning solvents with a hydrocarbon base.
6. Wipe the other exterior surfaces with a clean damp cloth. If the exterior surfaces require more thorough cleaning,
7. Return the rack slides and racks to their appropriate locations inside the oven.
8. LEAVE THE DOOR OPEN AT NIGHT AFTER CLEANING. This allows the oven to dry thoroughly after cleaning and also prolongs the life of the door gasket. If the equipment is not going to be used for a long period of time, it is advised to clean the equipment and surrounding areas properly.

NG CONVERSION KIT OR LPG CONVERSION KIT FOR GAS CONVERSION PARTS AND INSTRUCTIONS

WARNING

This conversion kit shall be installed by a qualified service agency in accordance with the manufacturer's instructions and all applicable codes and requirements of the authority having jurisdiction. If the information in these instructions is not followed exactly, a fire, an explosion or production of carbon monoxide may result causing property damage, personal injury or loss of life.

The qualified service agency is responsible for the proper installation of this kit. The installation is not proper and complete until the operation of the converted appliance is checked as specified in the manufacturer's instructions supplied with the kit.



CAUTION:

**ENSURE THE GAS SUPPLY IS SHUT OFF AT THE
MANUAL SHUT OFF VALVE BEFORE PROCEEDING
WITH THE CONVERSION**

A CONVERSION KIT is packed and placed inside the instruction tape.

- **If you buy a product that is configured with natural gas, it comes with the LPG CONVERSION KIT:**



- **If you buy a product that is configured with LPG, it comes with the NG CONVERSION KIT:**



Follow these steps:

- 1. Unplug oven from power and disconnect from gas line.**
- 2. Remove lower front burner cover.**

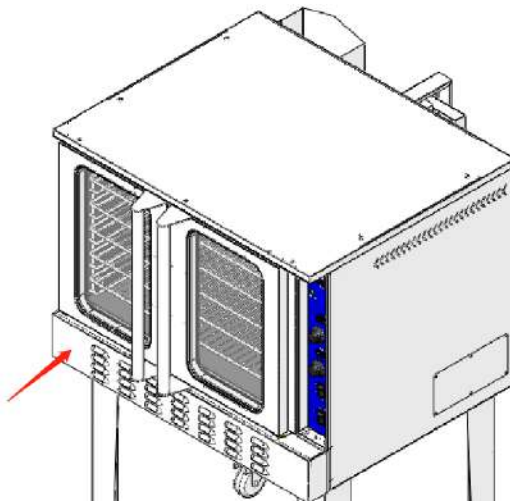

- 3. Open the doors and remove screws on top of the burner cover to remove the burner cover.**
- 4. Swing control panel forward. TO do this, reach under top and loosen control panel knob, then swing panel forward.**



5. Remove side panel of oven next to control panel by removing screws on bottom and rear of oven to expose the gas system and electrical system.

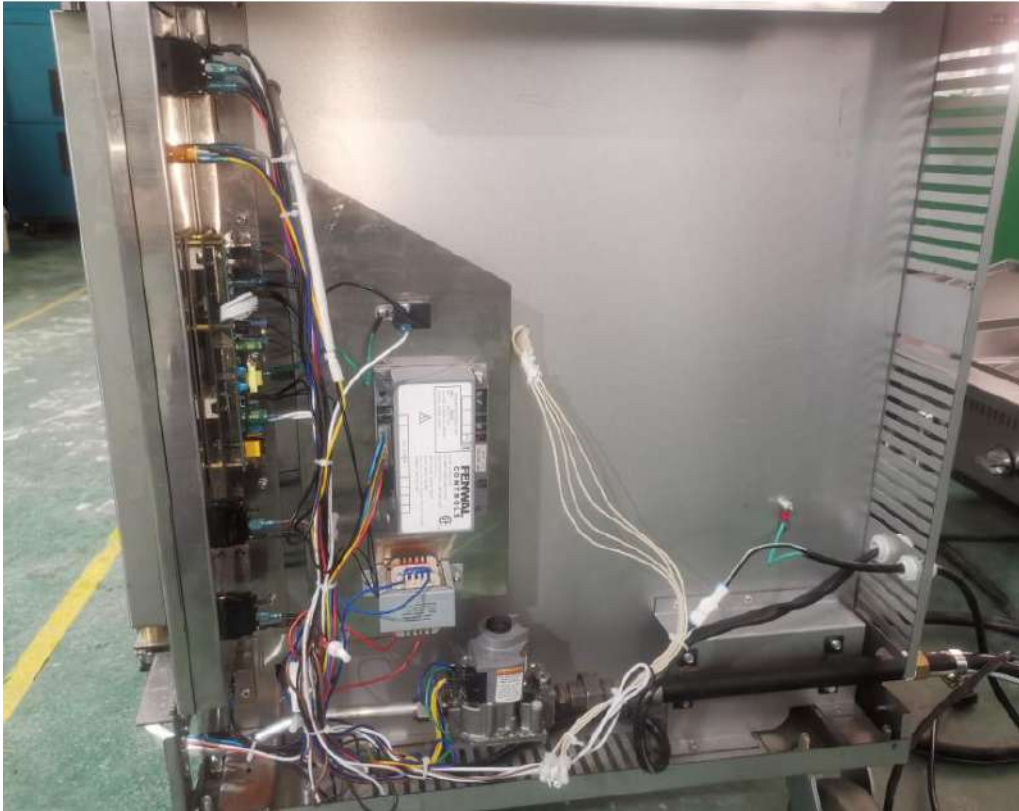

6. Using wrenches to loosen gas line connection to burner manifold.



7. Loosen nuts holding manifold pipe to bracket and remove screws in front of manifold bracket holding it to oven frame. Cut cable ties holding electrical wires to manifold assembly (remember where

they are so you can replace them with new cable ties during reinstallation.)

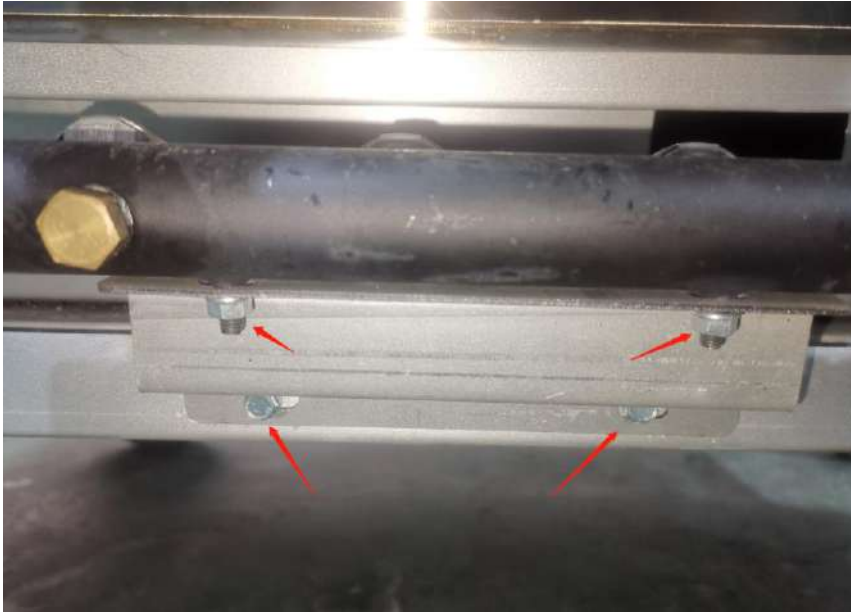

8. Pull manifold assembly off gas supply tube.
9. Using wrench to remove exiting gas orifices for NG(LPG), and replace with new LPG(NG) Gas orifices supplied in conversion kit. Use Loctite 542 thread sealer of equivalent to seal and lock new orifice threads.





- 10. On side of oven, locate gas control valve. Locate regulator screw cover on top. (Scrape out soft silicone filling screw driver slot) Use screwdriver to remove cover.**



- 11. After cover is removed, use a small screwdriver to carefully turn counterclockwise, the plastic spring retainer ring shown below.**



12. Keep turning until ring comes out and existing spring is exposed.

Remove the spring.

13. Locate the new regulator kit.

NG regulator kit:



LPG regulator kit:

14. Carefully remove the new spring in this bag, and place it where the old one was removed. Place the new spring retainer cap on top of the spring and carefully turn it clockwise to begin tightening the spring. Using a fine screwdriver, carefully tighten the retainer ring down.

- **After converting from LPG to NG, the regulator outlet pressure shall be 4" w.c.**
- **After converting from NG to LPG, the regulator outlet pressure shall be 10" w.c.**



15. TO make sure pressure from regulator is correct, remove brass pipe plug on burner manifold and connect sensitive gas pressure gage to measure manifold pressure.
16. Reconnect manifold to gas tube and reinstall manifold in oven, making sure orifices are correctly centered in burners, apply new cable ties to hold electrical wires to manifold.
17. Make sure all gas connections are tight and sealed. Reconnect oven to gas with maximum pressure coming into oven.
18. Plug oven into 120-volt outlet.
19. Turn on oven. Oven should light normally and operate normally if new regular spring and spring retaining cap were installed properly. Screw retaining cap down clockwise to increase pressure to manifold, turn counterclockwise to reduce pressure
 - If you convert LPG to NG, the manifold is 4" W.C.;

➤ **If you covert NG to LPG, the manifold is 10" W.C;**

Flames and combustion will be optimized

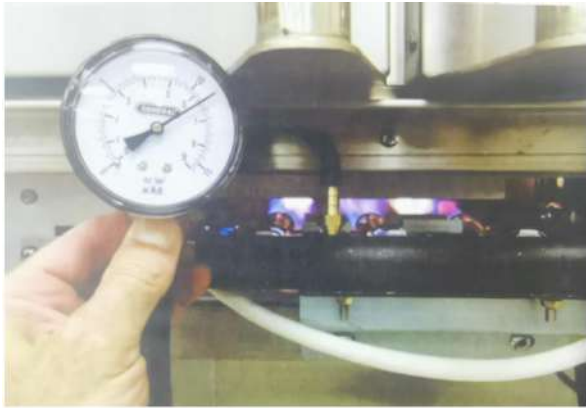

20. Turn off oven. Remove oven from gas supply.

21. Remove gas gage from burner manifold and replace with original brass pipe plug.

22. Replace side cover and swing control pane! back into normal position. Tighten retaining screw by hand on top of control panel to lock it into place.

DUKERS APPLIANCE CO., USA LTD
TOLL FREE: 1-800-931-8628 | FAX: 562-801-3026
INFO@DUKERSUSA.COM | WARRANTY@DUKERSUSA.COM
CORPORATE OFFICE: 2488 PECK ROAD, CITY OF INDUSTRY, CA 90601
WWW.DUKERSUSA.COM