

Half cube (.5" x 1" x 1")

## MODULAR ICE MACHINES

Model	Product ID	Cube	Capacity
KHM700-1A	300012	Half	668 Lbs/24 Hr

### STANDARD FEATURES

- Produces 'half cube' style ice cubes
- Enhanced water distribution improves water flow
- High efficiency evaporator helps limit wasted water and energy usage
- Easily removable panels increase ease of serviceability
- Advanced electronic board diagnoses all possible faults and controls all machine operations
- 304 stainless external frame for resistance



### WARRANTY

Kintera ice machines are warranted to be free from defects in material and workmanship under normal use and service for a period of 2 years for parts and labor. The compressor carries an additional 3 year warranty for the part only.

Items	Description
Refrigerant	R404A
Ambient Temp Range	41 - 109F
Water Temp Range	41 - 95F
Water Pressure Range	14.5 - 87 psi
Cubes Per Cycle	480
Approvals	NSF, ETL
Materials	304 Stainless Steel

Items	Description
Accessories Included	Ice Scoop
Compatible Ice Bins	KB300SS
	KB400SS
	KB500SS
	KB750SS
	KB900SS
	KB1050SS



RIGHT SIDE VIEW

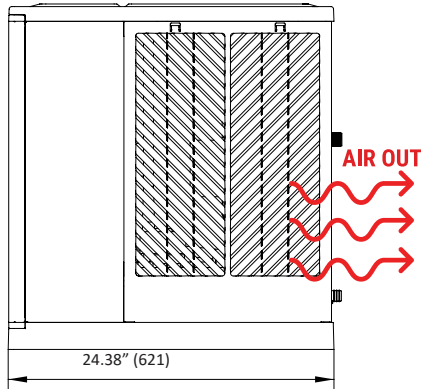

FRONT VIEW

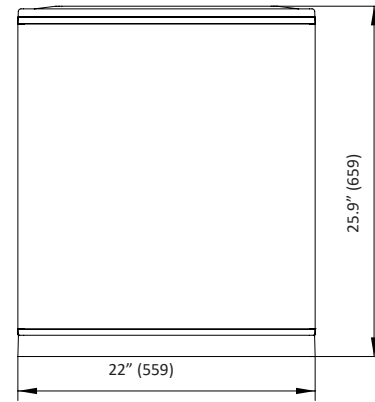

REAR VIEW

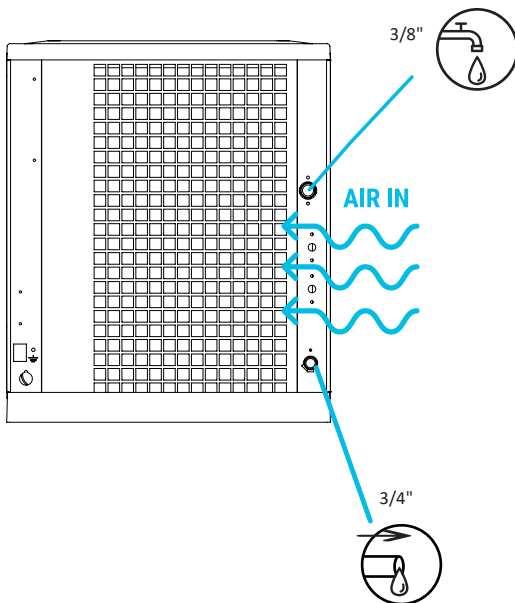

BOTTOM VIEW

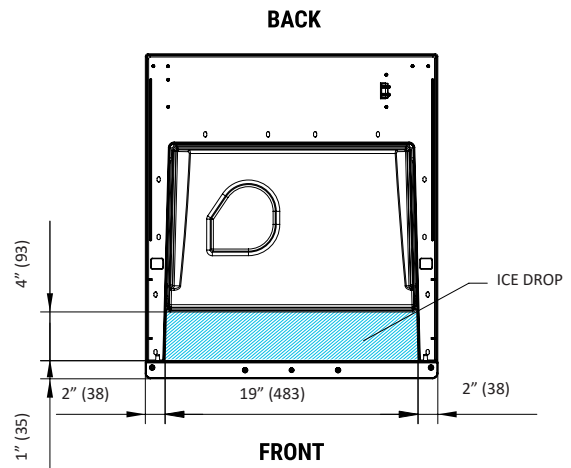

\* All dimensions in inches (and mm)

Model	Kwh/100 lbs	Water Usage (Gal/100 lbs)	Ice Production (70/50)	Ice Production (90/70)	External Dimensions			Circuit Wires	Voltage /Hz /ph	Amp	Heat Rejected (BTU/hr)	Net Weight (lbs)	Crated Weight (lbs)
					W	D	H						
KHM700-1A	6.73	16.6	668	553	22"	24.38"	25.9"	3	115/60/1	14.5	8,638	155.2	180

\*Crated dimensions (28 x 26 x 32)

\*\*Cubic Volume: 13.36ft

\*\*Freight Class 92.5

**Kintera Customer Service: (833) KINTERA (546-8372)**  
**Kintera Warranty Service: (866) 909-2855**

Kintera Food Equipment, LLC - 9 Hampshire St, Mansfield, MA, 02048

