

Model:

KS60MT

Food Prep Table:

Mega Top Solid Door Sandwich / Salad Unit



KS60MT



- **Stainless steel interior and exterior** retains attractive finish longer. Matching aluminium finished back
- **Rounded corner** design inside of the cabinet makes it easy to clean the inside storage room
- **Standard door features:**
Positive seal self-closing door(s) with 90° stay open feature.
Magnetic door gasket(s) removable without tools for easy of cleaning
- **R290 Refrigeration system** holds 33°F to 41°F (0.5°C to 5°C) for the best in food preservation.
- **Electronic control system:**
Adjustable temperature set point and defrost frequency
Error codes to diagnose service issues
- **Shelf:** Adjustable, heavy duty PVC coated shelves.
- **Standard heavy-duty casters** make it easy to move and clean underneath
- **Condensing unit** access in back of cabinet, slides out for easy maintenance
- **Insulated lid** on prep units helps maintain food freshness.

Rough-In Data

Specifications subject to change without notice.

Chart dimensions rounded up to the nearest 1/8" (millimeters rounded up to next whole number).

Model	Doors	Shelves	Cabinet Dimensions (inches) (mm)			CAP. CU.FT. LITER	HP	Voltage	Amps	NEMA Config.
			L	D	H					
KS60MT	2	2	60-1/4 1529	34 864	45-7/8 1166	15 428	1/3+	115/60/1	6.7	5-15P 

Plug type varies by country.



Intertek



Intertek

CONFORMS TO NSF/ANSI STD. 7

KINTERA EQUIPMENT, LLC

Add: PO BOX 1186, MANSFIELD MA 02048

Tel: 833-546-8372 Website: <https://kinteraequipment.com> E-mail: info@kinteraequipment.com

KS60MT Plan View

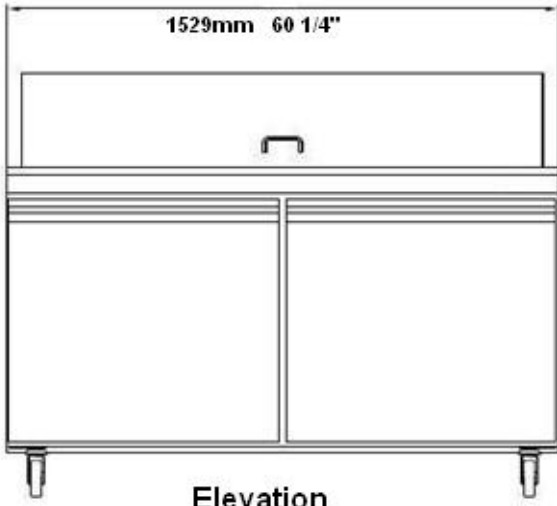

Elevation

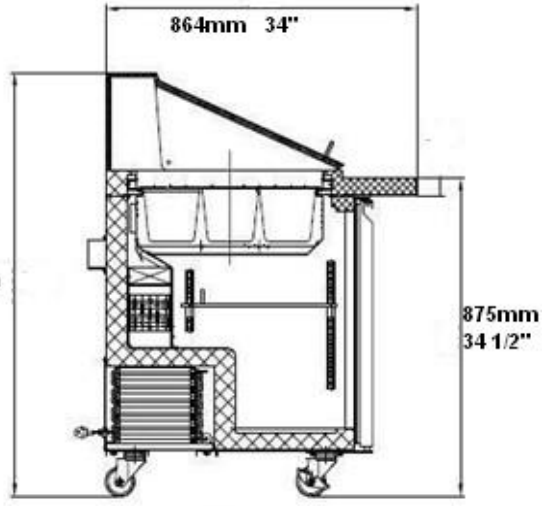

Section View

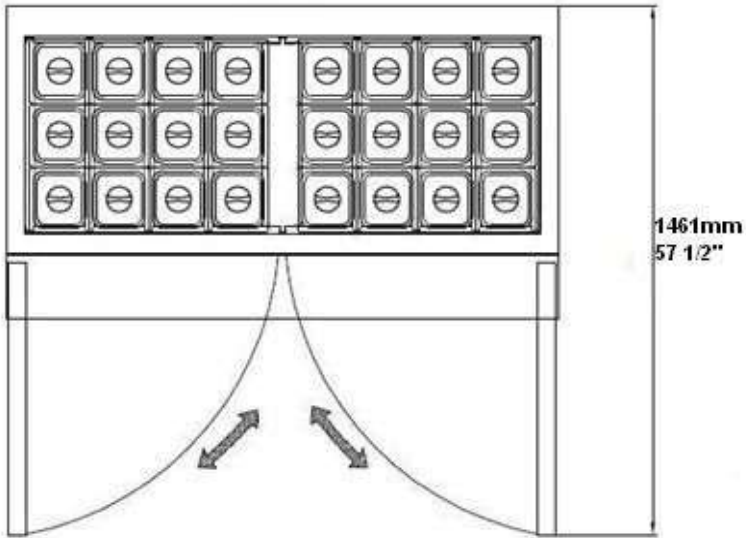

Plan

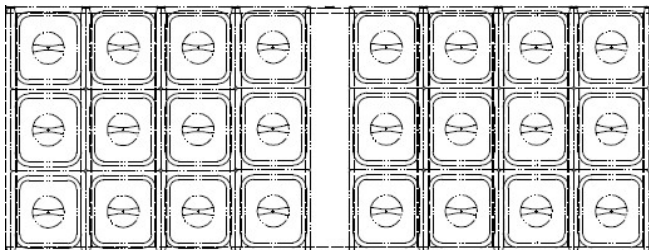

PAN LAYOUTS
24 (pcs) 1/6 pans