

Conveyor Toaster

STANDARD FEATURES

- 4-position toast selector switch: off / toast / buns / stand-by mode
- 3 1/2" clearance to accommodate high profile bread products
- Easy-to-load rack
- Front or rear discharge
- Permanently lubricated 50/60 Hz motor
- V-shaped reflectors help capture and redirect heat
- Long lasting serpentine metal sheathed heating element
- 4" adjustable legs
- Pilot light that signals unit is in operation
- Discharge and crumb trays are removable for easy cleaning
- 6' cord and plug
- Plug Configuration: NEMA 5-15P
- 1 year parts and labor warranty





KINTERA®

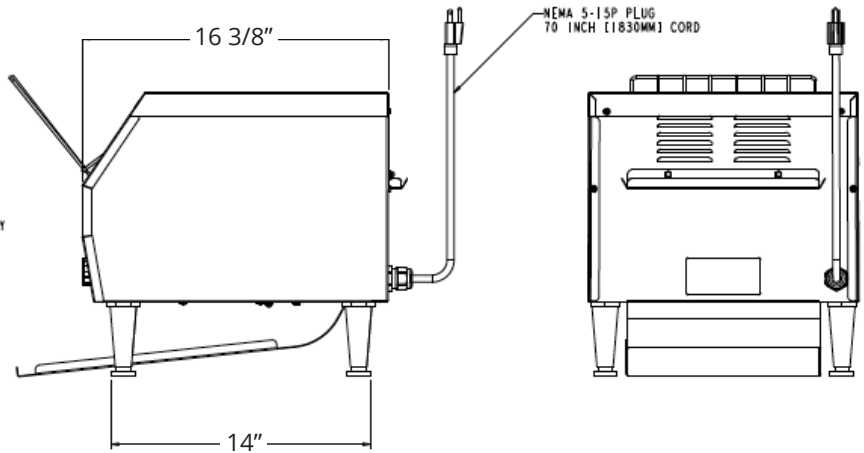
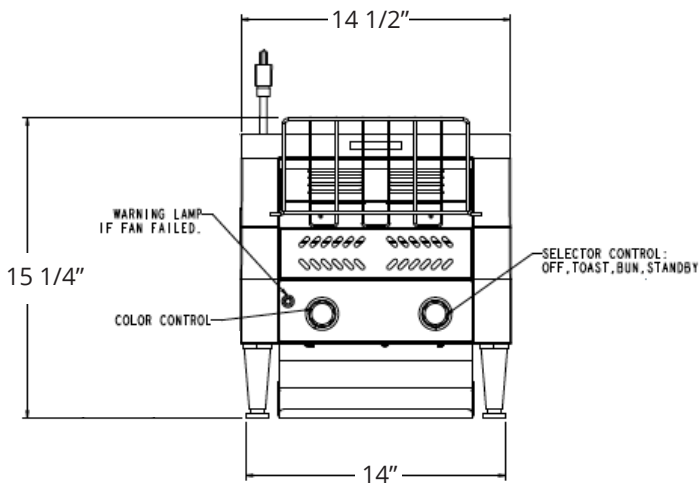
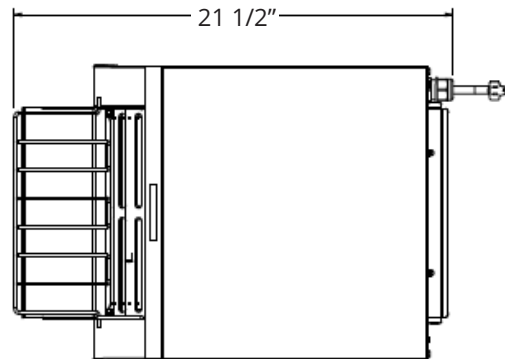
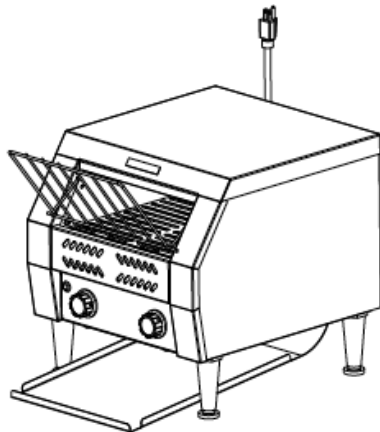

NEMA 5-15P

Model	Product ID	Dimensions							Specifications		Electric Rating			
		Width	Overall Depth	Unit Depth	Height	Chamber Width	Footprint	Footprint Depth	Type	Capacity	Volts	Watts	Hertz	Amps
KCT10-120	983192	14 1/2"	21 1/2"	16 3/8"	15 1/4"	10 3/8"	14"	14"	Bread	2 Slices	120	1790	50/60	14.9

Kintera Customer Service: (833) KINTERA (546-8372)

