



Direct Draw Coolers

Model	Product ID	Size
KDD2X	955406	58 7/8"

STANDARD FEATURES

- Standard, cabinet exterior construction includes attractive, wear resistant vinyl on steel in black finish with Stainless Steel top.
- Heavy-duty casters with brakes.
- Refrigeration system uses R290 refrigerant.
- Self-closing doors with locks.
- Dual angled faucets.
- Units wired at factory and ready for connection to a 115/60 phase.
- Side mount units with a 33°F to 38°F temperature range.
- NSF-7 approved for packaged and bottled product.
- Standard LED light inside of the cabinet.

WARRANTY

Kintera refrigeration equipment is warranted to be free from defects in material and workmanship under normal use and service for a period of 2 years for parts and labor. The compressor carries an additional 3 year warranty for the part only.



KDD2X



Front View

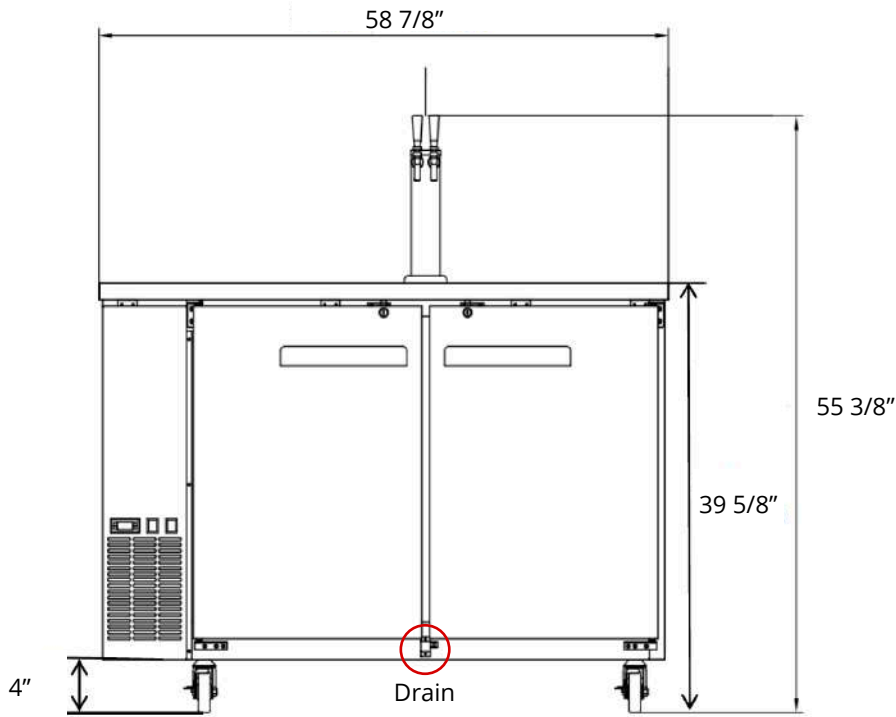

Side View

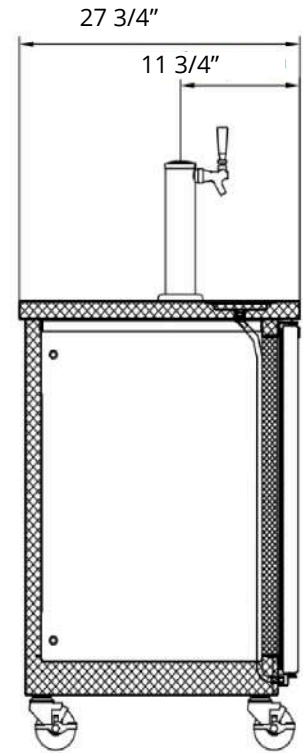

Top View

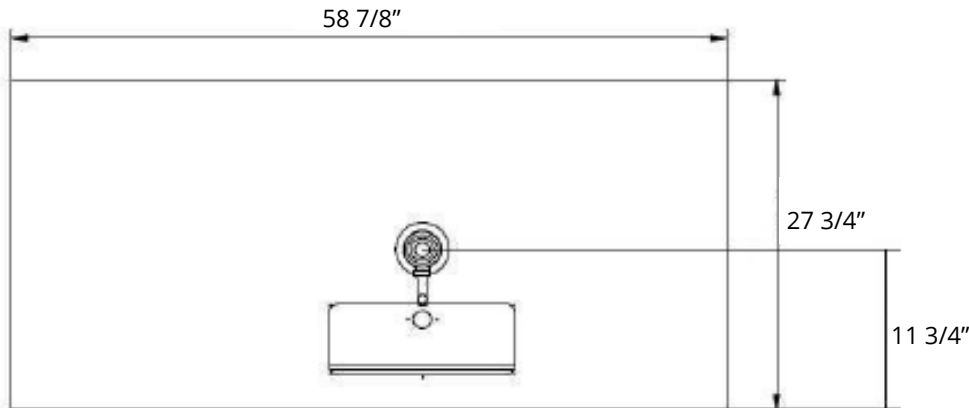

Model	Product ID	Doors	Shelves	Faucets	Capacity 1/2 Barrels	Cabinet Dimensions			HP	Voltage	Amps	NEMA Plug
						L	D	H				
KDD2X	955406	2	4	1	2	58 7/8"	27 3/4"	39 5/8"	1/3+	115/60Hz	2.88	

* Plug Type Varies by Country.