

UNDERCOUNTER FREEZERS

Model	Product ID	Size
KUC48F	919626	48" Unit

STANDARD FEATURES

- Solid state thermostat w/ digital display
- Stainless steel front & sides
- Self-closing doors remain open past 90°
- Environmentally friendly R290A
- EZ slide out condenser
- Whisper quiet
- Solid construction
- Full length integrated door handle
- Casters w/ two front brakes
- Cool air intake
- 2" clearance back & sides

KUC48F

WARRANTY

Kintera refrigeration equipment is warranted to be free from defects in material and workmanship under normal use and service for a period of 2 years for parts and labor. The compressor carries an additional 3 year warranty for the part only.

Items	Description	Items	Description
Front, top & sides	Stainless steel	Temperature control	Solid state thermostat w/ digital display
Doors	Stainless steel/ABS liner	Approvals	ETL
External back	Aluminum	Refrigerating system	Capillary tube
Cabinet interior	White aluminum	Refrigerant	R290A
Interior floor	300 Series stainless steel	Temperature range	-1°F to -7°F
Insulation	Polyurethane (CFC free)	Evaporator	Powder coated aluminum/copper
Shelves	Heavy duty, Epoxy coating	Condensing unit	Rear mounted

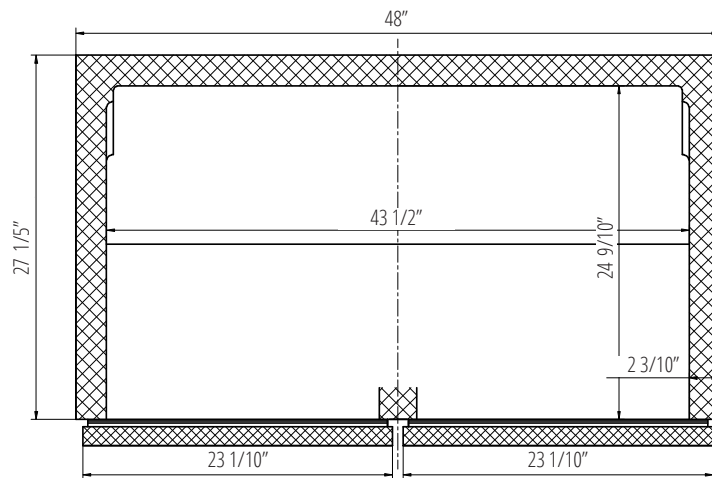
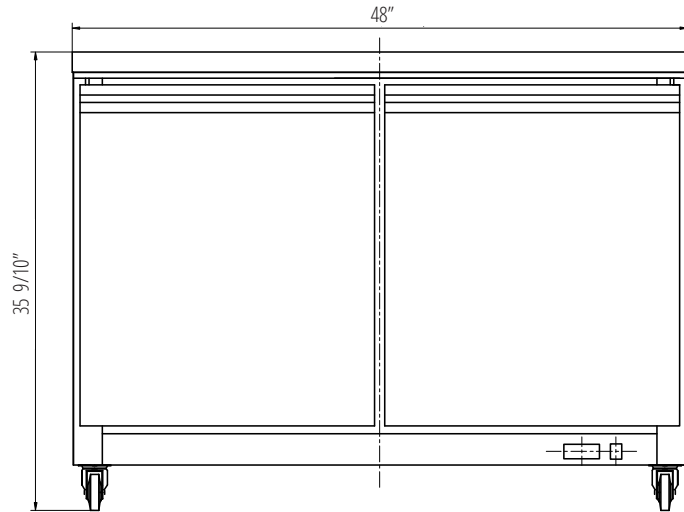

Model	Product ID	Doors	Capacity (cu ft)	Shelves	Cabinet Dimensions (in)			HP	Voltage	Amps	NEMA Plug	Cord Length (ft)	Crated Weight
					W	D	H						
KUC48F	919626	2	12	2	48	31	35 9/10	3/8	115/60/1	3	5-15P	10	340