

## UNDERCOUNTER REFRIGERATORS

Model	Product ID	Size
<b>KUC72R</b>	919624	71 7/10" Unit

### STANDARD FEATURES

- Solid state thermostat w/ digital display
- Stainless steel front & sides
- Self-closing doors remain open past 90°
- Environmentally friendly R600A
- EZ slide out condenser
- Whisper quiet
- Solid construction
- Full length integrated door handle
- Casters w/ two front brakes
- Cool air intake
- 2" clearance back & sides
- Heavy duty baked Epoxy coated wire shelves



**KUC72R**

### WARRANTY

Kintera Refrigeration equipment is warranted to be free from defects in material and workmanship under normal use and service for a period of 2 years for parts and labor. The compressor carries an additional 3 year warranty for the part only.

Items	Description	Items	Description
<b>Front, top &amp; sides</b>	Stainless steel	<b>Temperature control</b>	Solid state thermostat w/ digital display
<b>Doors</b>	Stainless steel/ABS liner	<b>Approvals</b>	UL-EPH
<b>External back</b>	Aluminum	<b>Refrigerating system</b>	Capillary tube
<b>Cabinet interior</b>	ABS	<b>Refrigerant</b>	R600A
<b>Interior floor</b>	300 Series stainless steel	<b>Temperature range</b>	34°F to 38°F
<b>Insulation</b>	Polyurethane (CFC free)	<b>Evaporator</b>	Powder coated aluminum/copper
<b>Shelves</b>	Heavy duty, Epoxy coating	<b>Condensing unit</b>	Rear mounted

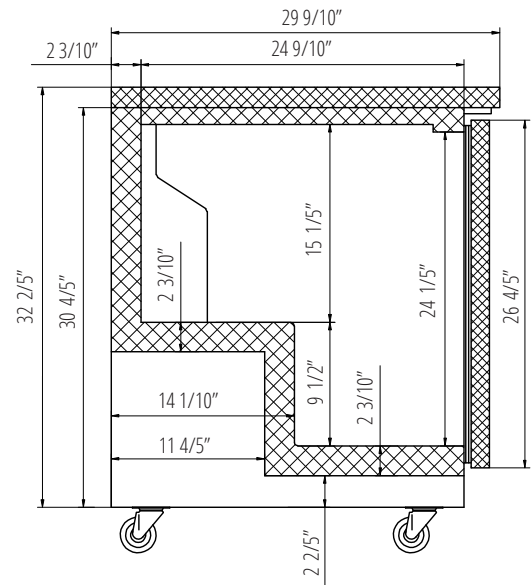
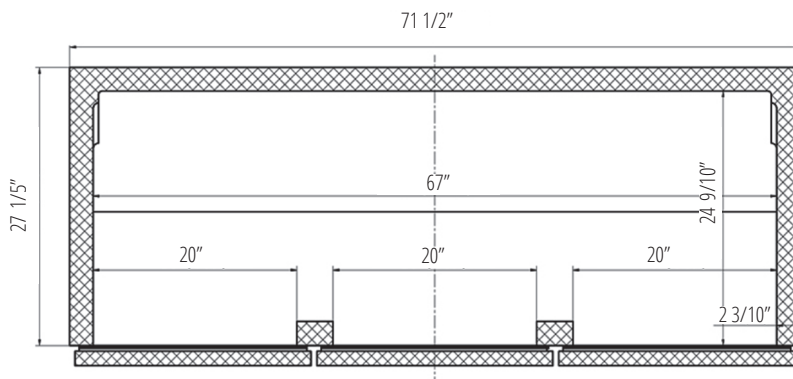
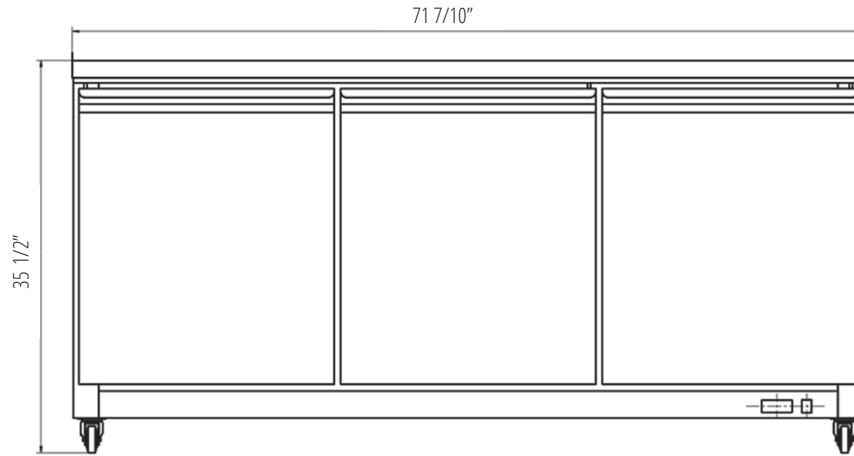

Model	Product ID	Doors	Capacity (cu ft)	Shelves	Cabinet Dimensions (in)			HP	Voltage	Amps	NEMA Plug	Cord Length (ft)	Crated Weight
					W	D	H						
<b>KUC72R</b>	919624	3	18	3	71 7/10	29 9/10	35 9/10	3/8	115/60/1	3.5	5-15P	10	380