

## 36" Chef Base

Model	Product ID	Size
KCB36X	955401	36 3/8"

### STANDARD FEATURES

- Stainless Steel interior and exterior retains attractive finish longer. Matching aluminum finished back.
- Rounded corner design inside of the cabinet makes it easy to clean the inside storage room.
- Cabinet top is one-piece, heavy duty reinforced stainless steel. Drip resistant "V" edge protects against spills.
- R290 Refrigeration system holds 33°F to 41°F for the best in food preservation.
- Electronic control system: Adjustable temperature set point and defrost frequency
- Standard drawer features: Heavy-duty pull handle drawer with tracks and rollers, this makes the drawer open and close easily.
- Each drawer fits one (1) 12"L x 20"W x 4"D full size and three (3) 6"L x 6"W x 4"D size food pans.
- Standard heavy-duty casters make it easy to bear the heavy cooking equipment, move and clean underneath.
- Easily accessible condenser coil for cleaning, and easy service access.
- Estimated Countertop weight limit: 880 lbs.



**KCB36X**

### WARRANTY

Kintera refrigeration equipment is warranted to be free from defects in material and workmanship under normal use and service for a period of 2 years for parts and labor. The compressor carries an additional 3 year warranty for the part only.



Front View

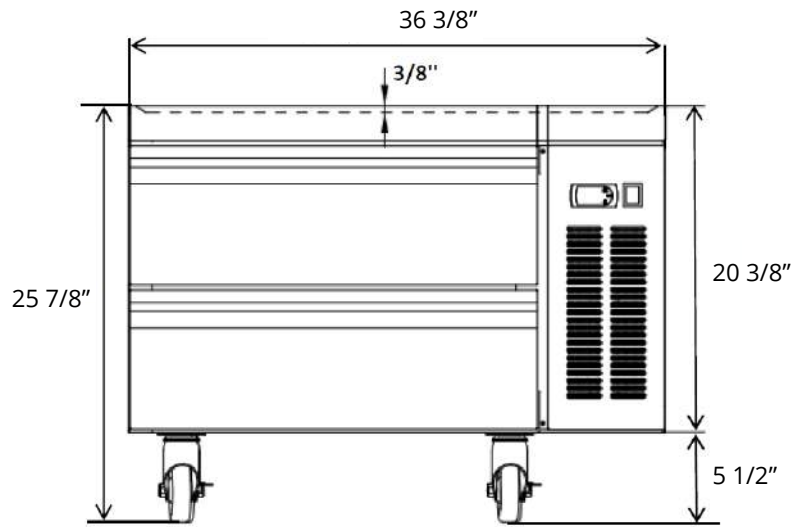

Side View

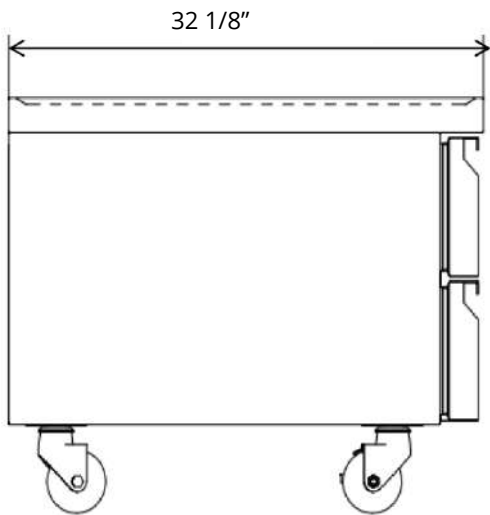

Top View

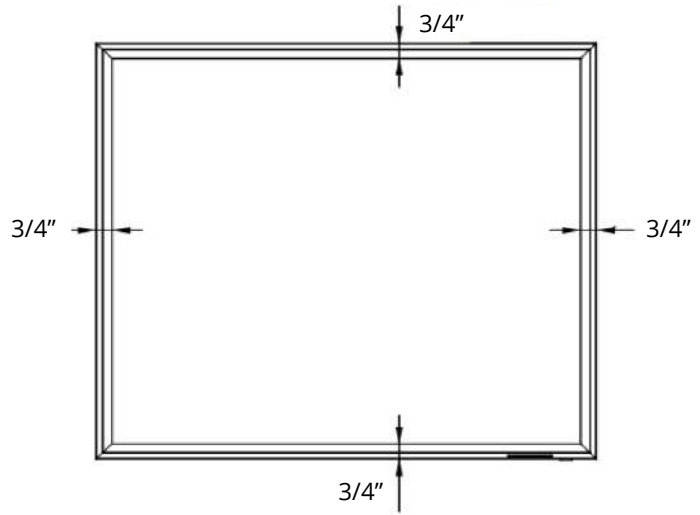

Model	Product ID	Drawers	Cabinet Dimensions			HP	Voltage	Amps	NEMA Plug
			L	D	H				
KCB36X	955401	2	36 3/8"	32 1/8"	25 7/8"	1/6	115/60/1Hz 220/50/1Hz	3.5	

\* Plug Type Varies by Country