



FOODWARMERS

INSTALLATION

&

OPERATIONS

MANUAL



"Your Solutions Partner"

Duke Manufacturing Co.

2305 N. Broadway • St. Louis, MO 63201

800.735.3853 • 314.231.1130 • 314.231.5074 fax

www.dukemfg.com

TABLE OF CONTENTS

	Page
Receiving and Inspection of Equipment	
Concealed Damage	4
Filing a Claim	4
Warning	4
General Troubleshooting .	4
Safety Precautions	
Gas Foodwarmers	5
Electric Foodwarmers	5
General Information	
Operation Instructions	5
Cleaning Instructions	5
Assembly Instructions for Aerohot Foodwarmers	6
Foodwarmer "Quick Base" Pictorial	7
Foodwarmer "Carving Board" Pictorial	8
Installation Instructions	
Aerohot Foodwarmers and Heritage Buffet Hot Food Units	9
Operating	
Aerohot Foodservice and Thurmaduke Foodwarmer	10
Installation of the Aerohot Sealed Wells Hot Food Units	11
Maintenance of the Aerohot Foodservice and Thurmaduke Foodwarmers	
Cleaning	12
Trouble Shooting Guide	12
Wiring Diagram for Aerohot Sealed Well Units	13
Parts Diagram and List for Wells	14
Gas Water Bath Hot Food Units	
Clearances	15
Gas Connections	15
Preheat Instructions	16
Lighting Instructions	16
Pilot Light Adjustment	16
Main Burner Adjustment	16
"ADI, "ASI" Installation Instructions	17
BM80 - Bottom Mount Hot Food Wells.	18
Gas Food Warmers (G, S-SR, T & TD, ASI, B-SR, CC-SR & 300 Series) – General Information	19
Operating Instructions – Gas Food Warmers	20
Stainless Steel Equipment Care and Cleaning	21
Cleaning Procedures for Polyethylene or ABS Rubber Composition Table Tops or Cutting Boards	24
Electric Parts List	25
Aerohot Foodservice Electric Parts Diagram	27
Heritage Buffet Unit Electric Parts Diagram	28
Thurmaduke Foodwarmer Electric Parts Diagram	29
Gas Parts List	30
Aerohot Foodservice Gas Parts Diagram	31
Thurmaduke Foodwarmer Gas Parts Diagram	32

RECEIVING AND INSPECTION OF THE EQUIPMENT

Even though most equipment is shipped boxed or crated, care should be taken during unloading so the equipment is not damaged while being moved into the building.

Carefully check for any visible signs of damage to the cartons or containers. If evidence of damage exists, the package should be opened immediately and a joint inventory and examination of the contents should be made by you and the driver.

CONCEALED DAMAGE

If a concealed loss or damage is discovered after you have given the carrier a clear delivery receipt, notify the carrier in writing immediately or within ten (10) days from the delivery date. If you phone the carrier, you must follow up the call in writing to protect your rights. You can only improve your position as a claimant by promptly reporting such loss or damage. You should also retain all cartons or containers, including packing material, until an inspection has been made or waived.

FILING A CLAIM

Notation of loss or damage does not constitute the filing of a claim. You should file your claim **in writing** with the carrier immediately!

Carriers will furnish the necessary form upon request. You should also request an inspection. If a claim is filed by phone, always follow up immediately in writing.

WARNING

Installation of this equipment should be done only by persons qualified or licensed to install electrical equipment.

Adjustments and service work should be performed only by a qualified service technician. Service is available through Duke Authorized Parts & Service Distributors throughout the United States. For a complete listing of these, consult your distributor listing or write to Duke for the name of the nearest distributor.

This equipment is intended for commercial use only. Not for household use.

GENERAL TROUBLESHOOTING

Always ask and check:

1. Is the unit connected to a live power source?
2. Check circuit breaker.
3. Is power switch on and pilot light glowing?
4. Check rating label. Are you operating the unit on the proper voltage?

GAS FOODWARMERS

FOR YOUR SAFETY

Do not store or use gasoline or other flammable vapors and liquids in the vicinity of this or any other appliance.

WARNING

Improper installation, adjustment, alteration, service or maintenance can cause property damage, injury or death. Read the installation, operating and maintenance instructions thoroughly before installing this equipment.

NOTICE

Due to the availability of parts, this foodwarmer may not have the ability to adjust the gas valve as described in the operations manual. All valves are factory pre-set to provide proper flame height with the type of gas listed on the nameplate.

ELECTRIC FOODWARMERS

CAUTION

To protect from possible severe electrical shock, this appliance is designed to be connected to a properly grounded electrical circuit.

For a cord connected appliance: In order to provide proper grounding, it is essential that the grounding prong of the plug be inserted into a properly grounded receptacle. If you do not know whether a receptacle is properly grounded, consult a licensed electrician.

NEVER insert the plug into a receptacle if the cord is frayed or damaged or if the plug has been altered or damaged.

GENERAL INFORMATION

1. Always clean equipment thoroughly before first use. (See general cleaning instructions.)
2. Check rating label for your model designation & electrical rating.
3. For best results, use stainless steel countertops.

GENERAL OPERATION INSTRUCTIONS

1. All foodservice equipment should be operated by trained personnel.
2. Do not allow your customers to come in contact with any surface labeled "CAUTION HOT".
3. Where applicable: Never pour cold water into dry heated units.
4. Where applicable: Do not cook, warm or hold food directly in liner pans (well pans). Always use steam table pans/insets, etc.
5. Never hold food below 150°F.

GENERAL CLEANING INSTRUCTIONS

1. **NEVER** clean any electrical unit by immersing it in water. Turn unit off before surface cleaning.
2. Always clean equipment thoroughly before first use. Clean unit daily, except where noted on charts: Use warm, soapy water. Mild cleansers and **PLASTIC** scouring pads may be used to remove baked-on food and water scale.
3. Turn off electrical units before cleaning or servicing.

ASSEMBLY INSTRUCTIONS FOR AEROHOT FOODWARMER UNITS

1. Place telescoping carton with printed side up and remove top. Remove foodwarmer from carton, and miscellaneous parts, etc., from heating compartments.
2. Flatten carton top and place it on floor. Place foodwarmer on the carton with top down.
- 3a. Attach four (4) leg angles to the body by sliding the ends of the leg angles inside the body corners between body and leg plate bracket. Each leg angle is fastened with four bolts already installed, but loose.
- b. Attach the undershelf to the other end of the leg angles. Use one bolt to line up and support the undershelf to the leg angles.
- c. Starting at one leg angle, remove the bolt and line up with leg or caster bracket to the holes on the undershelf and leg angle. Fasten each with two bolts.
- d. Repeat step "C" until all legs or casters are fastened in place.
- e. At this point, the unit may be set upright. If the unit has leg brackets it should be leveled by turning the adjustable feet as needed.
- f. The cutting board brackets should be attached with the screws already in place.
- g. If a pusher bar has been provided, it should be attached with the screws already in place.
- h. Push all knobs onto control stems.

AEROHOT & THURMADUKE

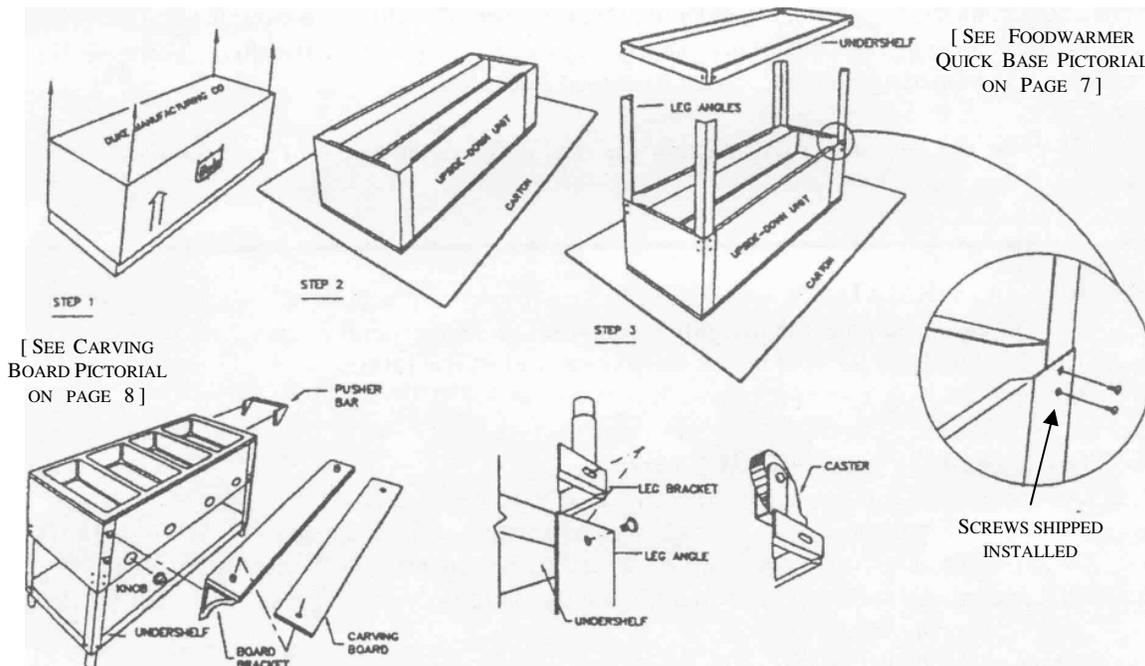

BE SURE ALL FASTENERS ARE TIGHTENED AS SECURELY AS POSSIBLE.

Your foodwarmer is now ready to be installed. Please read following Installation Instructions.

IMPORTANT

UNIT IS SHIPPED UNASSEMBLED. TO MEET NATIONAL SANITATION FOUNDATION STANDARDS, THE INSTALLER MUST USE A NSF-APPROVED SILICONE SEALANT TO SEAL THE SEAMS BETWEEN THE UNIT AND ASSEMBLED PARTS

FOOD WARMER QUICK BASE



1. Mount leg gussets to bottom shelf leaving screws loose.

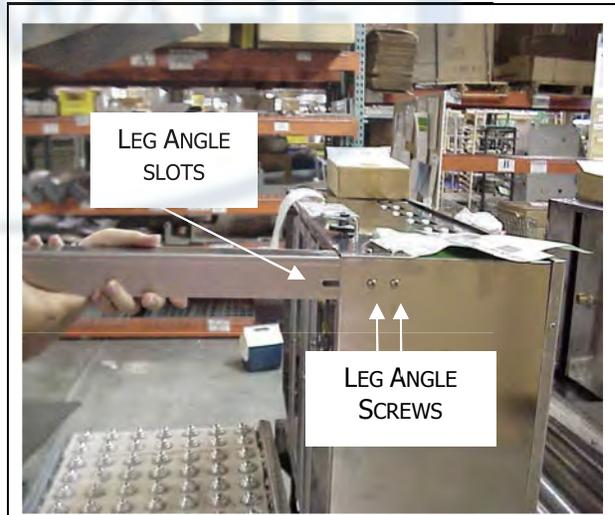

2. Leg angle screws will be shipped installed in the body unit but left loose for easy leg angle insertion. Insert leg between unit and bracket.



3. Slide bottom shelf over leg angle so that loose screws seat into leg angle slots. Tighten all screws.



4. Unit is ready to be turned right side up.

INSTALLATION OF CARVING BOARD



1. Remove bottom carving board bolts & top center screw.



2. Slide carving board bracket over top bolt (flat side of bracket to outside edge of warmer.)



3. Replace bottom carving board bolt and tighten. Repeat step 2 & 3 on opposite end of warmer.



4. Remove top bolts from Foodwarmer brackets. Place carving board into bracket slots.



5. Replace top bolts through brackets and carving board and into foodwarmer. Tighten.



6. Insert position pen into corners of carving board and hole of bracket. Secure with nut



7. Place polyboard over position pens.



8. Replace center screw through carving board into warmer. Tighten.

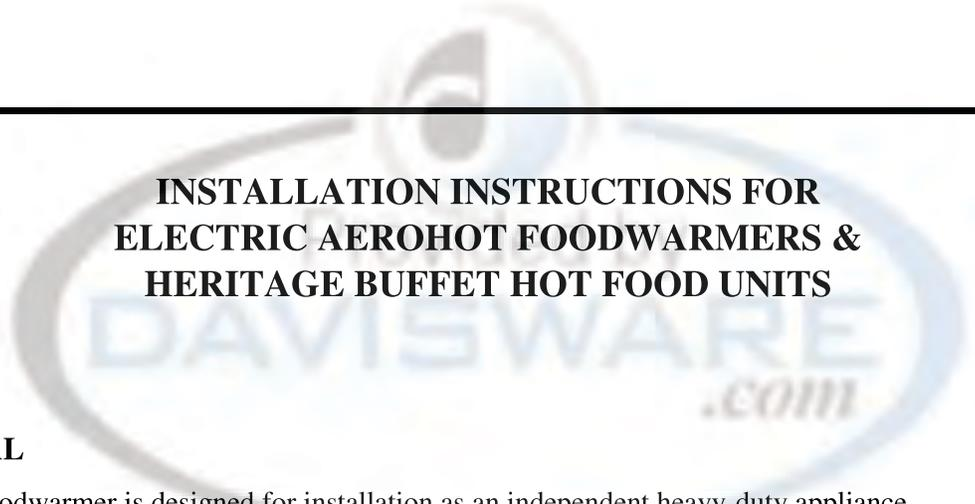

INSTALLATION INSTRUCTIONS FOR ELECTRIC AEROHOT FOODWARMERS & HERITAGE BUFFET HOT FOOD UNITS

GENERAL

This foodwarmer is designed for installation as an independent heavy-duty appliance.

For Heritage Buffet Units: Do not use alcohol or mineral spirits, or products with a high concentration of these solvents, to clean the body panels.

INSTALLATION

Operating temperatures permit safe installation of this foodwarmer within 1" of a combustible wall or partition.

Unit should be set adjusted to desired height, or to align with other equipment before it is permanently connected to electrical supply. For leveling the foodwarmer on an uneven floor or to eliminate rocking, turn the feet of the legs in the proper direction until the desired results are obtained.

ELECTRICAL CONNECTIONS

The voltage and wattage ratings of this foodwarmer are given on the device nameplate. Connect the foodwarmer to a circuit having a voltage and type of current (AC or DC) similar to that stamped on the device nameplate. For movable equipment a proper cord and cap are included for connection to the matching power supply outlet.

For permanent installations, connections to supply line may be made through conduit or armored cable. For supply connections use No. 12 AWG or larger wires suitable for at least 90°C (194°F). Use copper wire for power supply or suitable copper to aluminum wire connector.

Supply connections are made through a knockout in the junction box. The device leads extend into the junction box for making easy connections. After making and taping connections, push excess wire back into junction box and replace cover.

The body of the appliance should be grounded by connecting the ground wire provided in the junction box to a good electrical ground, such as a water pipe, a steam pipe, or a grounded supply conduit.

The foodwarmer is not fused and consequently must be connected to a fused circuit equipped with suitable disconnect means, as required by local code authorities.

OPERATING THE AEROHOT OR THURMADUKE

PREHEAT - To preheat individual sections, turn the switch dial to high for 10 - 20 minutes before the foods are placed in the compartments. Insure that pan openings are covered to prevent loss of heat.

ECONOMY OF OPERATION

WATER IS NOT NECESSARY IN THE AEROHOT FOODWARMER.

IF WATER IS USED, SPILLAGE PANS ARE REQUIRED.

Air, being easier and quicker to heat than water, makes the waterless foodwarmer faster and more economical to operate than a table using water.

Foods can be kept moist by keeping them at the correct temperature. Foods dry out only when excessive temperatures are reached, so when foods tend to dry out, **REDUCE HEAT**.

If only part of the foodwarmer is needed, the compartment not in use need not be heated. Insulation between the compartments divide the unit into a series of smaller independent foodwarmers.

CARE AND CLEANING

Care should be used to prevent spilling when placing full food containers into the pan openings. Spilled foods that are not removed will dry out and eventually burn, causing odors. The inside of the heating compartments should be wiped out daily and thoroughly cleaned at least once each week.

SWITCH SETTINGS

The most satisfactory switch settings must be determined by experience based on the nature of the foodservice and the type of operation as well as individual preference of the restaurant operator. The proper switch setting necessary to keep foods at the desired temperature will vary dependent upon the frequency of turnover, size of food containers, amount of food in each container, room temperature, location of foodwarmer with respect to range or other heated equipment, air outlets, fans, doors and passageways.

SWITCH DIAL SETTINGS		RECOMMENDED TEMPERATURES (in degrees)	FOODS OR TYPES OF FOODS
Covers ON	Covers OFF		
Lo	2	140° - 150°F	Rolls - Thick Soups Creamed Foods - Mashed Potatoes
2-3	4-5	150° - 170°F	Roasts* - Short Ribs - Sliced Meats Baked Ham* - Fish - Vegetables - Cutlets Stews - Baked Beans - Croquettes Fried Liver - Fried Potatoes Fried Chicken Medium Gravies
3-4	4-6	170° - 200°F	Baked Potatoes - Barbecued Ribs Dressing - Thin Gravies and Soups

* A low perforated rack is recommended to keep roasts and hams off the bottom of the pan. When a rack is used, keep 1" - 2" of thin gravy in the bottom of the pan.

INSTALLATION OF AEROHOT SEALED WELL UNITS

Check unit's electrical rating tag to insure that electrical service is of the proper voltage and adequately sized for this equipment.

LOCATION

Do not install the hot food unit near any combustible objects or surfaces affected by heat or moisture.

LEVELING

This unit must be level, both front and back and left to right, in order to maintain an equal water depth throughout the wells.

UNITS WITH DRAINS

A 1/2" female pipe thread drain is supplied on all models. The installer must provide a suitable drain connection and shut-off valve. **CAUTION:** Over tightening or failure to use proper tools may result in damage to the weld where the drainpipe is connected to the well. **This equipment is to be installed to comply with applicable Federal, State or Local Plumbing Code.**

ELECTRICAL CONNECTION

Connections must be made in accordance with all applicable local codes and/or the National Electrical Code. Refer to the wiring diagrams on the following pages.

OPERATION

Before the unit is used for the first time, turn the temperature knob to "10" and heat the well for 20-30 minutes. Do not be alarmed if smoke appears; this preheat should burn off any residue or dust on the heating element.

WARNING: Steam can cause serious burns. Always wear some type of protective covering on your hands and arms when removing lids or pans from the unit. Lift the lid or pan in a way that will direct escaping steam away from your face and body.

Never place food directly into the well. Always use pans.
Wet operation is recommended.

Always place covers on pans when not serving to prevent food from drying out and to reduce your operating costs.

For most efficient operation, keep empty, covered insets in each well during preheating and when the well is not in use.

WET OPERATION

1. Fill food well with two (2) quarts of water. For quicker pre-heating, use hot water to fill the well.
2. Turn the control to "HIGH" and pre-heat the warmer for 30 minutes.
3. After pre-heating, set the control to your desired serving temperature.
4. Never pour water into a well that has been heated dry. This may cause well to crack and leak.
Always fill well before preheating or before water level is below 1/2".

DRY OPERATION

1. Pre-heat the well on "HIGH" for approximately 15 minutes.
2. After pre-heating, set the control to your desired serving temperature.

MAINTENANCE OF AEROHOT AND THURMADUKE HOT FOOD UNITS

DAILY CLEANING

1. Turn the control knob to the OFF position and allow unit to cool before cleaning.
2. Drain or remove water from the well.

CAUTION: Do not allow water to splash or run on to the controls or wiring.

3. Use a soft cloth or sponge with a mild detergent to clean the entire warmer assembly. Rinse completely with warm water and then dry.
4. A plastic scouring pad and a mild detergent may be used to remove hardened food.

NOTICE: Do not use steel wool.

WEEKLY CLEANING

1. Scale deposits due to the mineral content of the water may be removed using a plastic scouring pad and a de-scaling agent approved for use on stainless steel. It is important to keep these deposits from building up as they may cause corrosion of the stainless steel well.
2. After de-scaling, the well assembly should be rinsed thoroughly with a solution of vinegar and water to neutralize all cleaner residue.
3. Wipe the well assembly dry and leave uncovered.

WARNING

Do not use any highly caustic cleaners, acids or ammonia. These may cause corrosion and/or damage to the stainless steel well. Do not allow water to stand in the well for long periods of time. Water must be removed from the well and the well cleaned after each use.

TROUBLE SHOOTING GUIDE

1. Problem: Pilot light off and unit does not heat:
 - a. Has unit been connected to a proper electrical source of the proper voltage?
 - b. Is electric turned on at the main? Check the circuit breaker or fuse.
 - c. Are the master switch and/or control knobs set to the "ON" position?
2. Problem: Unit does not maintain proper food temperature.
 - a. Are the controls set to the proper setting?
 - b. If used with water, was hot water used to fill well? If not, allow extra pre-heat time.
 - c. Has unit been pre-heated for 30-45 minutes?
 - d. Were pans of food placed into unit at or above desired temperature?
 - e. Has the food been kept covered?
 - f. Are there air conditioning ducts, take-up air ducts or fans located near or over unit, causing cool drafts?
 - g. Has unit been connected to a proper electrical source of the proper voltage? If so, is there a "low" voltage condition?

WIRING DIAGRAM FOR SEALED WELL AEROHOT FOOD SERVICE HOT FOOD UNIT

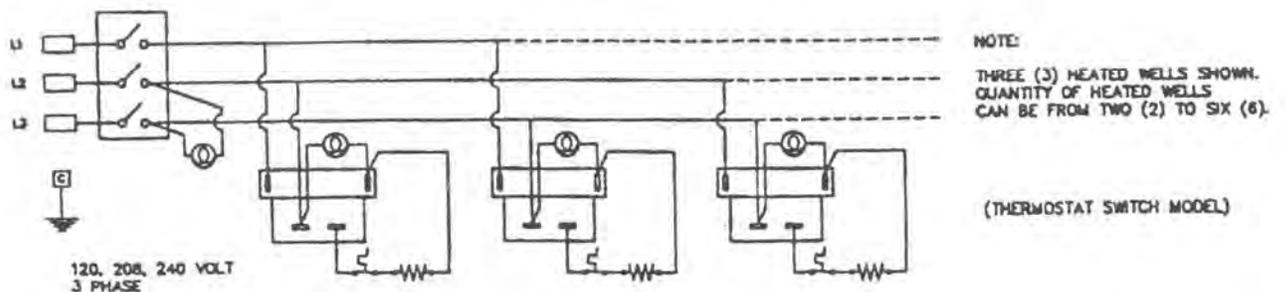
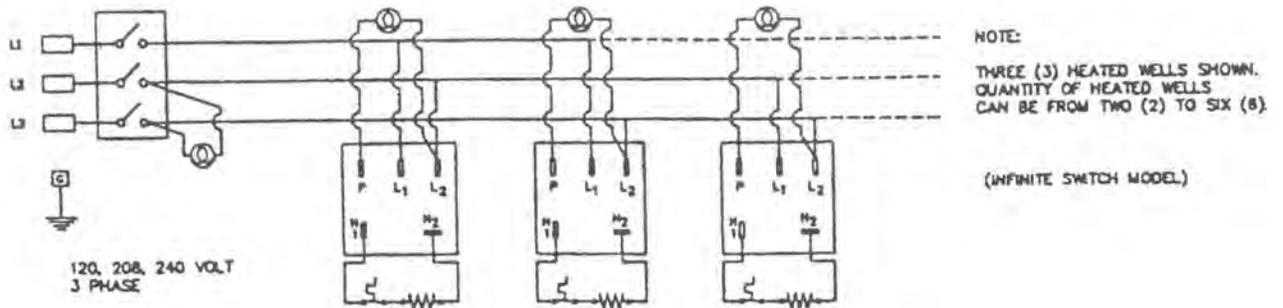
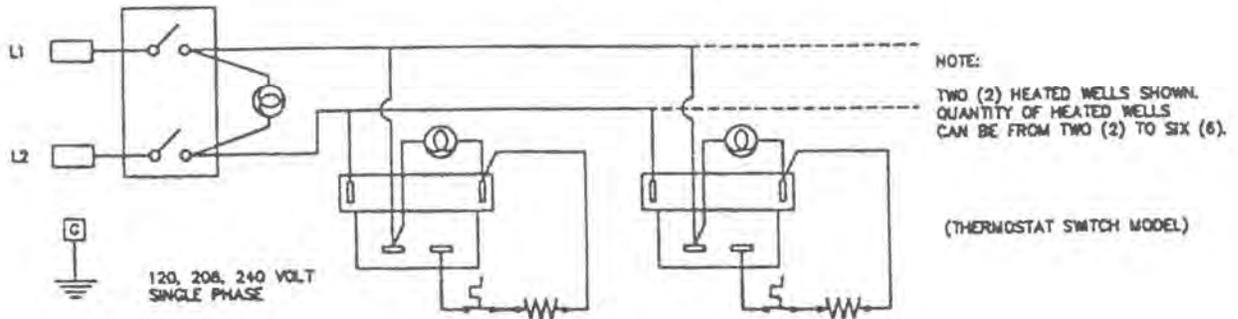
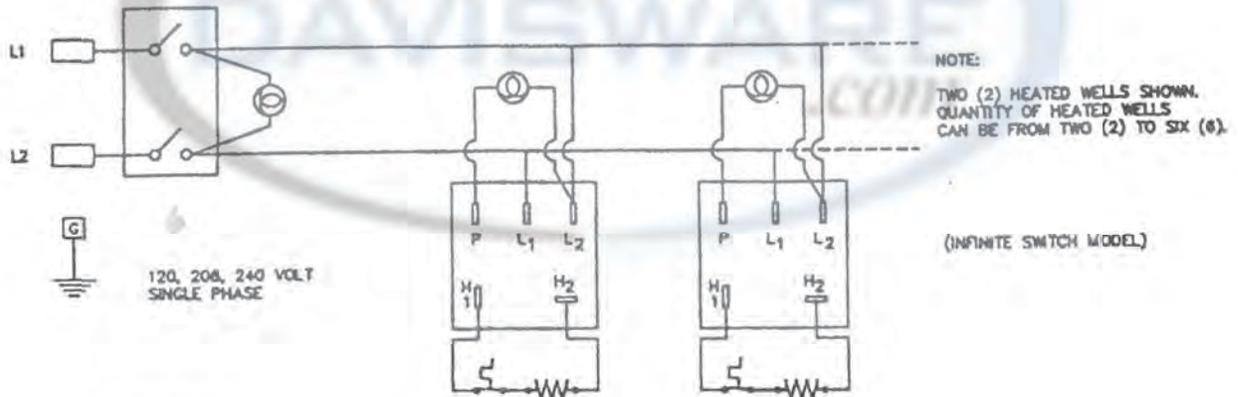

PARTS

#	Part#	Part Name
1	154047	Food well, with drain
2	215550	Pilot, 120V
3	215555	Pilot, 240V
4	212081	Thermostat
5	212190	T-Stat Knob

INFINITE SWITCHES

6A	155580*	120v
6B	155578	208V
6C	155579	240V
7	212164	Infinite Switch knob
8	153471	Hi-Limit thermostat
9	154458	Nut w/star washer
10	230162	Element pan

ELEMENTS

12	154352	120, 750 WATT
13	154046	120V, 1200 WATT
14	154353	208V, 750 WATT
15	154355	240V, 750 WATT
16	154354	240V, 1200 WATT
17	154048	Strainer

* - ALTERNATE PART #'S

212074 - 5580 -2

212076 - 5578-2

212075 - 5579-2

212081 - 2081-2

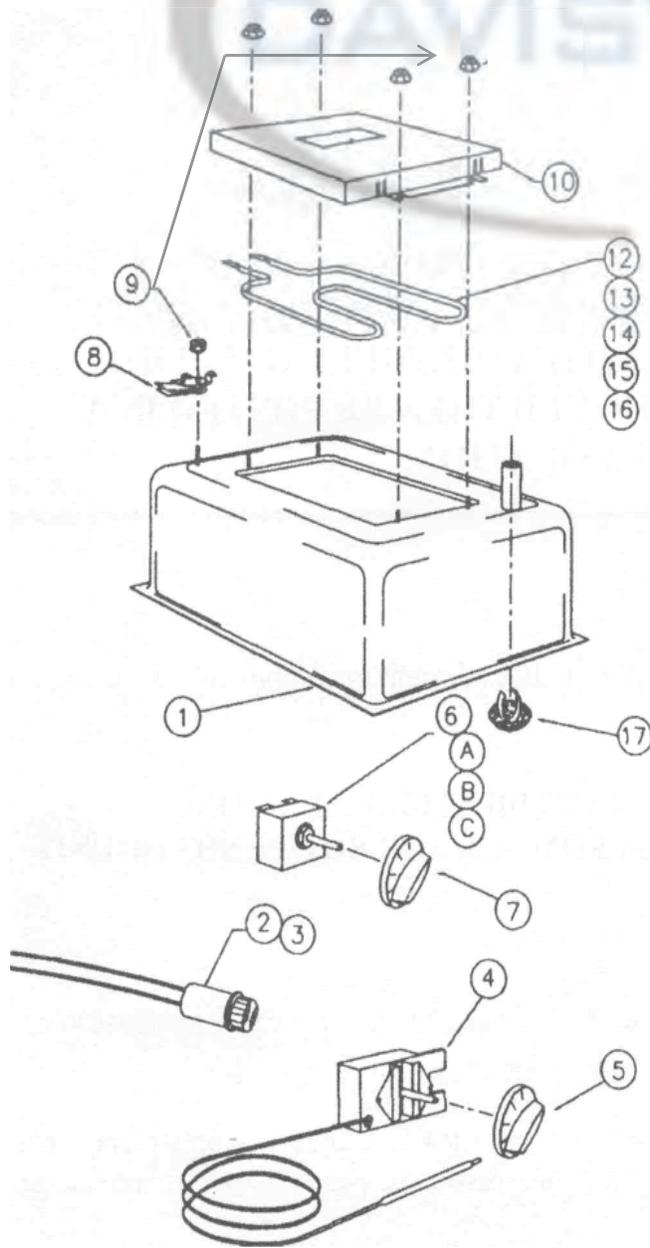

GAS WATER BATH HOT FOOD TABLE

FOR YOUR SAFETY

Do not store or use gasoline or other flammable vapors and liquids in the vicinity of this or any other appliances.

WARNING

Improper installation, adjustment, alternation, service or maintenance can cause property damage, injury or death. Read these instructions thoroughly before installing or servicing this equipment.

IMPORTANT

BEFORE PLACING THIS APPLIANCE INTO OPERATION CONTACT YOUR LOCAL GAS SUPPLIER AS TO WHAT INSTRUCTIONS ARE TO BE FOLLOWED IF YOU SMELL GAS. THE INSTRUCTIONS OBTAINED SHOULD THEN BE POSTED IN A PROMINENT LOCATION.

CLEARANCE INSTRUCTIONS:

APPLIANCES TO BE INSTALLED ON COMBUSTIBLE FLOORS AND/OR ADJACENT TO COMBUSTIBLE WALLS OR PARTITIONS:

ALLOW MINIMUM 2" CLEARANCE FROM COMBUSTIBLE AND NON-COMBUSTIBLE WALLS OR PARTITIONS FROM REAR AND BOTH ENDS OF UNIT.

The appliance area must be free and clear of all combustible items.

The unit must be leveled before placing into operation. To level the unit on an uneven floor, adjustable feet have been provided.

The appliance and its individual shut off valve must be disconnected from the gas supply piping system during any pressure testing of that system at test pressures in excess of 1/2 pound per square inch gauge.

The appliance must be isolated from the gas supply system by closing its individual manual shut-off valve during any pressure testing of the gas supply system at test pressures equal to or less than 1/2 pound per square inch gauge.

GAS CONNECTION:

INSTALLATION PERSONNEL: Check all connections and fittings on valves and tubing supplied as a part of this unit to make sure they did not come loose during shipment. A manual shut-off valve should be provided between the gas supply system and the gas inlet on the appliance. A pressure regulator has been provided with this unit and must be installed to ensure proper operation. All piping should be clean and free of burrs and metal chips. All pipe connections should be made using a joint compound resistant to the action of LP gasses. A drip tee must be used to collect any moisture or particles. After completing the installation of the unit all connections must be checked for leaks. Use a commercial brand leak detector or a solution of liquid detergent and water to check for leaks. **DO NOT USE AN OPEN FLAME TO CHECK FOR LEAKS.**

When installing this unit, all local codes must be followed. In the absence of local codes, the installation must conform to the latest edition of ANSI Z223.1 - booklet titled, "THE NATIONAL FUEL GAS CODE". This publication is available from the American Gas Association, 1515 Wilson Blvd., Arlington, VA 22209.

Provisions for adequate air supply must be taken into account when installing the unit. Care should be taken so as not to obstruct the area around the burner or pilot. DO NOT close off the space between the undershelf and lower edge of the body. A minimum of 4" air space must be maintained between items stored on the undershelf and the burner. Combustible items should NOT be stored on the undershelf. Do not block off the louvered air vents on the rear and ends of the unit as this will affect the operation of the burner and could cause it to go out due to lack of oxygen.

See schematic drawing of the burner and manifold assembly for the location of the various components.

PREHEAT INSTRUCTIONS

Fill water compartment with minimum 2" of HOT water.

NOTE: Water is necessary to operate this unit. Failure to use water or allowing the compartment to dry will damage the unit and void the warranty.

Turn the burner control knob to the "HIGH" position for 15-30 minutes with the pan openings covered before pans containing hot food are placed in the unit. This will retain heat in the unit and be more efficient. Adjust burner control knob to maintain foods at desired temperatures.

LIGHTING INSTRUCTIONS

To light pilot, push in red reset button on bottom of safety pilot valve body and light pilot. Hold reset button in for approximately 30 seconds, then release. If the pilot flame goes out, repeat the above procedure until the pilot stays on. When the pilot flame stays burning, a valve disc will open, permitting gas to flow to the burner. To activate the main burner, turn the burner control valve to HIGH position, then MEDIUM or LOW as desired. Be certain to check for proper burning.

NOTE: If pilot or burner goes out, turn off all gas and wait five (5) full minutes before attempting to relight.

The pilot light and main burners were preset and tested at the factory. However, due to vibrations, etc., in shipping and handling, they should be rechecked upon installation of the unit and readjusted as required.

PILOT LIGHT ADJUSTMENT

To adjust the pilot, first remove the cap screw from the safety pilot valve body located on the underside near the pilot inlet. The adjustment screw is inside. Insert a small screwdriver into the slot and turn to adjust the height of the pilot flame. The pilot flame should be high enough to prevent it from blowing out due to drafts or ventilating fan air movement. Excessive height of the pilot flame is simply wasting energy.

NOTE: Due to the pilot light burning at all times, it is important to be certain to put a small amount of water (approximately 1/4" deep) into the pan after cleaning. Under no circumstances should the water pan be dry. This will cause discoloration of the stainless steel and possible damage to the unit as well as voiding the warranty.

MAIN BURNER ADJUSTMENT

With burner on, turn control knob to LOW position, then remove knob from stem. Insert small screwdriver into hollow stem or burner control valve and engage screw slot. Turn screw clockwise to increase height. Ensure that valve stem does not turn while adjusting. At this time also adjust the air shutter at the end of the burner for proper air-gas mixture. Observe the flame and open or close the air shutter until only tiny yellow tips appear on the flame.

CAUTION: Do not operate main burner without water in the pan. This will cause damage to the unit and void the warranty.

"ADI "ASI UNITS INSTALLATION INSTRUCTIONS

WHEN MOUNTING FROM BELOW THE COUNTER TOP:

The top surface of the unit should have applied to it a generous bead of a silicone rubber sealant such as Dow Corning "RTV" or G.E. Silicone sealant. After clamping the unit up against the counter top, wipe from the joint any excess sealant, which squeezes out. The unit mounted in this manner should be supported from below by an appropriate metal structure or hung from the underside of the top by mounting angles of at least 18-gauge steel.

WHEN MOUNTING BY THE OVERHANGING TOP RIM (in a cut-out in the counter top):

The underside of the overhanging top rim should have applied to it a generous bead of silicone before the unit is set into the cutout in the counter top. In order to relieve part of the load from the top rim, the unit should be supported from below with metal components in a manner compatible with the construction of the counter. Any excess sealant, which squeezes out between the unit top rim and counter top, should be wiped off before the sealant cures or stripped away with a sharp knife after curing.

If the above instructions are followed, application 1 does not require any additional support. However, caution must be used to insure that the top cutout is the proper size as listed below:

1 -section	17"L x 23"W (front to back)
2 -section	31"L x 23"W (front to back)
3 -section	45"L x 23"W (front to back)
4 -section	59"L x 23"W (front to back)
5 -section	73"L x 23"W (front to back)
6 -section	87"L x 23"W (front to back)

Be sure the unit is centered in the opening in the counter top. If support from below is used for application 2, or because the cutout is cut too large, caution must be used to avoid supporting the unit against any of the gas or electric components.

The gas units **MUST** have 35 square inches of air space per burner for proper ventilation. The gas unit is manufactured with permanently attached spacer legs, which provide the required area. It is mandatory that the area directly below the operator's controls, between these legs, remains open at all times. The remaining three (3) sides of the unit may be enclosed by the cabinet housing the unit.

MODELS BM80 BOTTOM MOUNT HOT FOOD WELLS

INSTALLATION

1. Follow general installation instructions.
2. Install in an all stainless steel counter top.
3. Turn down edges of counter top into well pan. Use 1" radius-ed corners or square corners depending on the bottom mount well you selected.
4. Apply 1/4" bead of silicone sealant to top flange of unit and position unit underneath counter.
5. Secure unit to counter with stainless steel fasteners.
6. Mount control as indicated and connect power. Again, check rating label for correct voltage.

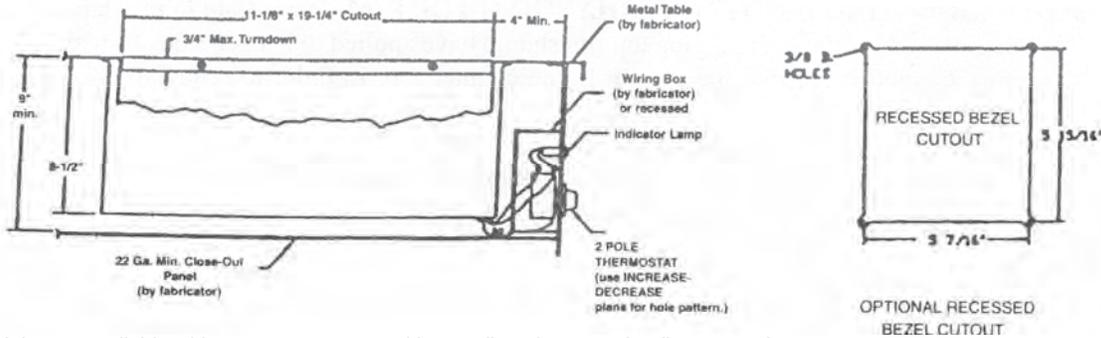
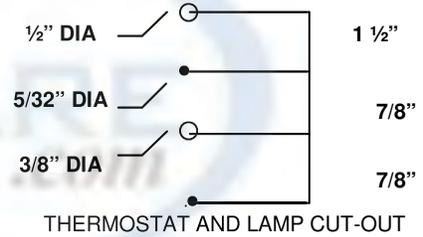

Units are available with square corners or with 1" radiused corners for die-stamped cutouts.

GENERAL SPECIFICATIONS (ALL 80 Series)							
OUTSIDE DIMENSIONS	INSIDE DIMENSIONS	CUTOUT	FLANGE	RECOM FLANGE TURNDOWN	STANDARD CONTROL LOCATION	CONTROL CUTOUT	
13-13/16" X 21-3/4" X 8-3/16"	12-3/16" X 20-1/8" X 6-1/4"	11-7/8" X 19-7/8"	13/16"	3/4"	36" Capillary 26" Effective Length	Use Increase/Decrease Plate for Hole Pattern	
OPTION SPECIFICATIONS		DRAIN LOCATION	DRAIN COUPLING	THERMOSTAT	RECESSED BEZEL*	ELECTRICAL CODE KIT	SHIP WT
ROUND CORNERS	SQUARE CORNERS	1-11/16" x 1-11/16" From back right corner	1/2NP NPT Stainless 1-1/2" long	W/72" Capillary effective length 62". Add "S" to Stock #	See Above, Stock #56370 Ship Wt. 2 lbs.	Add "E" to applicable Stock No.	19 lbs.
1" Radiused. Standard on stock #s 55486, 55485, 55354, 55360, 56299	3/4" DOWN. Standard on stock #s 55352, 55355m, 55358, 55361, 56288. Standard stock #s with drains: 55353, 55356, 55359, 55362, 56297						
WIRING SPECIFICATIONS				ELECTRICAL SPECS PER UNIT			
HEATING WELLS	BOTTOM HOUSING			STOCK	VOLTS	WATTS	1PH/AMPS
1 piece, die stamped. 304 stainless, 20 gauge HEATING ELEMENTS: 1600W tubular heating element 1200W tubular heating element 900W tubular heating element 750W tubular heating element Tubular heating elements. Silicone fluid (or equivalent) sealed heating elements. Screw terminal connectors. Manufactured in accordance with UL standards.	BOTTOM HOUSING: Fully insulated, galvanized steel, insulated on bottom of inspection housing.			55486 55351 55352 55353	120V	750W	6.25
	THERMOSTATS: Equipped with an all-position, using point system and permanently dual, 250V, 25AMP, double pole.			55485 55354 55355 55356	120V	1200W	10
	THERMOSTAT: Thermostat is 2 pole and breaks both lines at "OFF" position. Units are pre-wired to Thermostat. Make line connections, as shown. All wiring should be done in accordance with local codes. Use minimum 14SWC copper wire rated at least 908			55481 55357 55358 55359	208V 240V	1200W 1600W	5.77 6.67
	Optional recessed bezel equipped with 1" conduit knockouts.			55480 55360 55361 55362	208V 240V 277V	900W 1200W 1600W	4.33 5.0 5.9
				56300 56299 56298 56297	120V	1600W	13.3

ANY UNIT SHIPPED PRIOR TO MARCH 1, 2003 WILL NEED THE OLD STYLE PAN. (PN 154043)

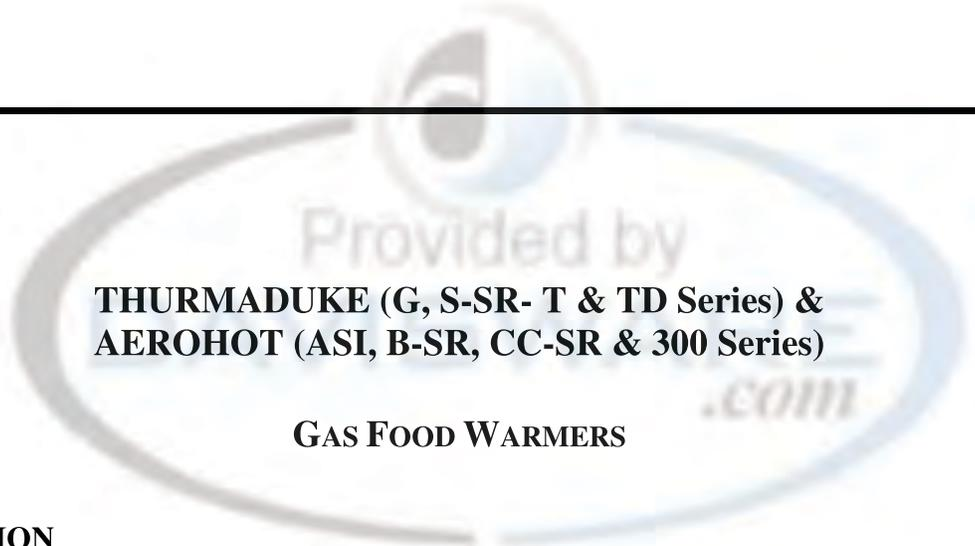

**THURMADUKE (G, S-SR- T & TD Series) &
AEROHOT (ASI, B-SR, CC-SR & 300 Series)**

GAS FOOD WARMERS

INSTALLATION

The Thurmaduke (G, S-SR, T & TD Series) and Aerohot (ASI, B-SR, CC-SR & 300 Series) must be installed with a minimum horizontal clearance of 1" from combustible and non-combustible construction, but may be installed against a wall or partition in fireproof locations. For Canada only, the Aerohot (ASI, B and CC Series) units are to be installed in non-combustible locations only.

Units should be adjusted to desired height, or to align with other equipment. Insure that unit is level. For leveling on an uneven floor or to eliminate rocking, turn the feet of the legs in the proper direction until the unit is the desired height and is level and all feet are in contact with the floor.

A pressure regulator is provided and must be installed in the gas line, adjacent to the Thurmaduke or Aerohot series. The regulator for use with natural gas is set with a manifold pressure of 3.7 in W.C.P. The regulator for use with propane gas is set with a manifold pressure of 10 in. W.C.P. A regulator is not required for CGA LP gas units.

GAS CONNECTIONS

PLUMBER OR INSTALLER: Insure that all connections and fittings on valves, burners, and tubes are tight and have not become loose in shipment. Connect gas pressure regulator, gas shut-off valve and ground joint union in supply line for convenience in servicing unit. Pipe components and compounds used should be resistant to the action of liquefied petroleum gases. Install a drip tee to collect dirt and moisture in the gas. Regulator must be installed so as to be readily removable. A soap solution should be used for checking for gas leaks in pipe connections. See "Operating Instructions" for proper flame height, etc.

GAS PARTS

This Thurmaduke and Aerohot Series is equipped with correct burners and gas pressure regulator for the type gas shown on the AGA nameplate. Consult the AGA plate to insure that unit is equipped with the correct parts. Each burner is rated at 3500 BTU per hour maximum input and needs no adjustment. The set orifice, fixed secondary air entrainment, cap slots and pressure regulator will automatically provide for correct BTU input.

The gas pressure regulator supplied with this unit is to be connected in the supply line of the foodwarmer to insure satisfactory operation (The warranty covering this unit does not apply if the pressure regulator is not installed in the line or the pressure settings are changed.)

OPERATING INSTRUCTIONS
SECTIONAL – VALVE – BURNER - PILOT ASSEMBLY
VALVE ADJUSTMENT FOR APPROXIMATE FLAME HEIGHT

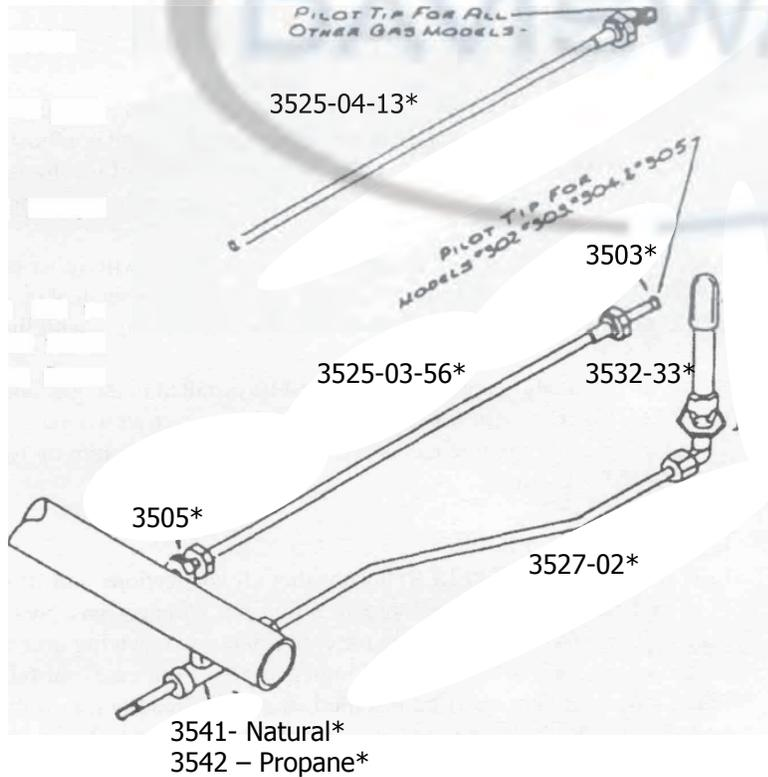

1. Turn valve knob to low or medium position.
2. Remove valve knob.
3. Insert small screwdriver into hollow stem of valve and engage screw slot.
4. Turn to right to decrease and left to increase flame height. Insure that valve stem does not turn also. Observe flame while making adjustment.

** For replacement of these parts refer to the coinciding number.*

The most satisfactory flame heights must be determined by experience based on the nature of the food service and the type of operation as well as the individual preference of the restaurant operator. The flame size necessary to keep foods at the desired temperature will vary dependent upon the frequency of turn over, size of food containers, amount of food in each container, room temperature, location of food warmer with respect to range or other heated equipment, air outlets, fans doors and passageways.

SWITCH DIAL SETTINGS		RECOMMENDED TEMPERATURES (in degrees)	FOODS OR TYPES OF FOODS
Covers ON	Covers OFF		
Lo	2	140° - 150°F	Rolls - Thick Soups Creamed Foods - Mashed Potatoes
2-3	4-5	150° - 170°F	Roasts* - Short Ribs - Sliced Meats Baked Ham* - Fish - Vegetables – Cutlets Stews - Baked Beans - Croquettes Fried Liver - Fried Potatoes Fried Chicken Medium Gravies
3-4	4-6	170° - 200°F	Baked Potatoes - Barbecued Ribs Dressing - Thin Gravies and Soups

* A low perforated rack is recommended to keep roasts or hams off the bottom of the pan. When a rack is used, keep 1" - 2" of thin gravy in the bottom of the pan.

DUKE Stainless Steel Equipment Care and Cleaning

Contrary to popular belief, stainless steels ARE susceptible to rusting. Corrosion on metals is everywhere. It is recognized quickly on iron and steel as unsightly yellow/orange rust. Such metals are called “active” because they actively corrode in a natural environment when their atoms combine with oxygen to form rust.

Stainless steels are passive metals because they contain other metals, like chromium, nickel and manganese that stabilize the atoms. 400 series stainless steels are called ferritic, contain chromium, and are magnetic; 300 series stainless steels are called austenitic, contain chromium and nickel; and 200 series stainless, also austenitic, contains manganese, nitrogen and carbon. Austenitic types of stainless are not magnetic, and generally provide greater resistance to corrosion than ferritic types.

With 12-30 percent chromium, an invisible passive film covers the steel’s surface acting as a shield against corrosion. As long as the film is intact and not broken or contaminated, the metal is passive and stain-less. If the passive film of stainless steel has been broken, equipment starts to corrode. At its end, it rusts.

Enemies of Stainless Steel

There are three basic things which can break down stainless steel’s passivity layer and allow corrosion to occur.

1. Mechanical abrasion
2. Deposits and water
3. Chlorides

Mechanical abrasion means those things that will scratch a steel surface. Steel pads, wire brushes and scrapers are prime examples.

Water comes out of the faucet in varying degrees of hardness. Depending on what part of the country you live in, you may have hard or soft water. Hard water may leave spots, and when heated leave deposits behind that if left to sit, will break down the passive layer and rust stainless steel. Other deposits from food preparation and service must be properly removed.

Chlorides are found nearly everywhere. They are in water, food and table salt. One of the worst chloride perpetrators can come from household and industrial cleaners.

So what does all this mean? Don’t Despair!

Here are a few steps that can help prevent stainless steel rust.

1. Use the proper tools.

When cleaning stainless steel products, use non-abrasive tools. Soft cloths and plastic scouring pads will not harm steel’s passive layer. Stainless steel pads also can be used but the scrubbing motion *must* be in the direction of the manufacturers’ polishing marks.

2. Clean with the polish lines

Some stainless steel comes with visible polishing lines or “grain.” When visible

lines are present, always scrub in a motion parallel to the lines. When the grain cannot be seen, play it safe and use a soft cloth or plastic scouring pad.

3. Use alkaline, alkaline chlorinated or non-chloride containing cleaners. While many traditional cleaners are loaded with chlorides, the industry is providing an ever-increasing choice of non-chloride cleaners. If you are not sure of chloride content in the cleaner used, contact your cleaner supplier. If your present cleaner contains chlorides, ask your supplier if they have an alternative. Avoid cleaners containing quaternary salts; it also can attack stainless steel and cause pitting and rusting.

4. Treat your water. Though this is not always practical, softening hard water can do much to reduce deposits. There are certain filters that can be installed to remove distasteful and corrosive elements. To insure proper water treatment, call a treatment specialist.

5. Keep your food equipment clean. Use alkaline, alkaline chlorinated or non-chloride cleaners at recommended strength. Clean frequently to avoid build-up of hard, stubborn stains. If you boil water in stainless steel equipment, remember the single most likely cause of damage is chlorides in the water. Heating cleaners that contain chlorides have a similar effect.

6. Rinse, rinse, rinse. If chlorinated cleaners are used, rinse and wipe equipment and supplies dry immediately. The sooner you wipe off standing water, especially when it contains cleaning agents, the better. After wiping equipment down, allow it to air dry; oxygen helps maintain the stainless steel's passivity film.

7. Never use hydrochloric acid (muriatic acid) on stainless steel.

8. Regularly restore/passivate stainless steel.

Recommended cleaners for specific situations

Job	Cleaning Agent	Comments
Routine cleaning	Soap, ammonia, detergent, Medallion	Apply with cloth or sponge
Fingerprints & smears	Arcal 20, Lac-O-Nu Ecoshine	Provides barrier film
Stubborn stains & discoloration	Cameo, Talc, Zud, First Impression	Rub in direction of polish Lines
Grease & fatty acids, blood, burnt-on-foods	Easy-off, De-Grease It Oven Aid	Excellent removal on all finishes
Grease & oil	Any good commercial detergent	Apply with sponge or cloth
Restoration/Passivation	Benefit, Super Sheen	

Review

1. Stainless steels rust when passivity (film-shield) breaks down as a result of scrapes, scratches, deposits and chlorides.
2. Stainless steel rust starts with pits and cracks.
3. Use the proper tools. Do not use steel pads, wire brushes or scrapers to clean stainless steel.
4. Use non-chlorinated cleaners at recommended concentrations. Use only chloridefree cleaners.
5. Soften your water. Use filters and softeners whenever possible.
6. Wipe off cleaning agent(s) and standing water as soon as possible. Prolonged contact causes eventual problems.

To learn more about chloride-stress corrosion and how to prevent it, contact the equipment manufacturer or cleaning materials supplier.

CLEANING PROCEDURES FOR POLYETHYLENE OR ABS (RUBBER) COMPOSITION TABLE TOPS OR CUTTING BOARDS

When high pressure cleaning equipment is not available; use hot water, a granular cleanser or detergent and a stiff bristle brush. (Abrasive action is necessary, as simply wiping the board will not suffice.) After scrubbing, rinse thoroughly with hot water. Allow to lie flat.

Several excellent germicidal cleaners are also available, including Calgon's "Big Cat" and Johnson's "Break Up". Clorox is another good cleaner and is USDA approved.

The tabletop material is cut into sections not larger than 36" in any plane, and no section weighs more than fifty (50) pounds. These are stipulations of the National Sanitation Foundation to facilitate cleaning.

The tops should be turned over daily to reduce possibility of warping and should never be stood on end.

Periodically, go over the board with a clean, flat stainless steel scraper to help seal some of the knife marks.

The use of cleavers on synthetic boards or tabletops is not recommended.

ELECTRIC PARTS LIST

Note: Always include Plate Data Specifications when ordering Replacement Parts.

<u>PART #</u>	<u>ALTERNATE</u>	<u>PRODUCT LINE</u>	<u>DESCRIPTION</u>
2164		AEROHOT, HERITAGE	Knob for infinite switch
155580		AEROHOT, HERITAGE	Infinite Switch, Robert Shaw or EGO #101, 110-118V
155578		AEROHOT, HERITAGE	Infinite Switch, Robert Shaw or EGO #359, 208V
155579		AEROHOT, HERITAGE	Infinite Switch, Robert Shaw or EGO #102, 240V
2113		THURMADUKE	Master Toggle Switch (AC/DC), 1 Ph
2100		THURMADUKE	Master Toggle Switch (AC/DC), 3 Ph
2190*		AEROHOT, THURMADUKE	Knob for #2081 Thermostat
2081*		AEROHOT, THURMADUKE	Thermostat, Robert Shaw or Sunne
2080*		AEROHOT, THURMADUKE	Thermostat, Robert Shaw #D-18, with knob and pilot (440V – 480V)
<i>* For Canadian Models Built Prior to 3/1983</i>			
2070	5550	THURMADUKE	Pilot Light, round, Amber, 120V, sectional
2071		THURMADUKE	Pilot Light, round, Red, 120V, master
215555		THURMADUKE	Pilot Light, round, Amber, 240V, sectional
2069	5556	THURMADUKE	Pilot Light, round, Red, 240V, master
2108		AEROHOT, THURMADUKE	Figure 8 Element, 480V, 1000 Watt
2237		AEROHOT, THURMADUKE	Loop Element, 118V, 500 watt
2244		AEROHOT, THURMADUKE	Loop Element, 208V, 500 watt
2245		AEROHOT, THURMADUKE	Loop Element, 240V, 500 watt
2238		AEROHOT, THURMADUKE	Loop Element, 118V, 750 watt
2239		AEROHOT, THURMADUKE	Loop Element, 208V, 750 watt
2240		AEROHOT, THURMADUKE	Loop Element, 240V, 750 watt
2243		AEROHOT, THURMADUKE	Loop Element, 118V, 1000 watt
2241		AEROHOT, THURMADUKE	Loop Element, 208V, 1000 watt
2242		AEROHOT, THURMADUKE	Loop Element, 240V, 1000 watt
2402		AEROHOT, HERITAGE, THURMADUKE	Dome Element, 118V, 500 watt
2409		AEROHOT, HERITAGE, THURMADUKE	Dome Element, 208V, 500 watt
2410		AEROHOT, HERITAGE, THURMADUKE	Dome Element, 240V, 500 watt
2403		AEROHOT, HERITAGE, THURMADUKE	Dome Element, 118V, 750 watt
2420		AEROHOT	CTFW Element, 120V, 750 watt for TAH-1HFSS models only "W" shaped
2426		AEROHOT	Dome Element, 115V, 1200 watt for TAH-1HFSS models only. "W" shaped
2404		AEROHOT, HERITAGE, THURMADUKE	Dome Element, 208V, 750 watt
2405		AEROHOT, HERITAGE, THURMADUKE	Dome Element, 240V, 750 watt
2408		AEROHOT, THURMADUKE	Dome Element, 120V, 1000 watt
2406		AEROHOT, THURMADUKE	Dome Element, 208V, 1000 watt
2407		AEROHOT, THURMADUKE	Dome Element, 240V, 1000 watt
21-26-12			Wire Harness, 2-Section, 120V
21-26-13			Wire Harness, 2-Section, 208V
21-26-14			Wire Harness, 3-Section, 120V

ELECTRIC PARTS LIST

Note: Always include Plate Data Specifications when ordering Replacement Parts.

<u>PART #</u>	<u>ALTERNATE</u>	<u>PRODUCT LINE</u>	<u>DESCRIPTION</u>
21-26-15			Wire Harness, 3-Section, 208V
21-26-16			Wire Harness, 4-Section, 120V
21-26-17			Wire Harness, 4-Section, 208V
21-26-18			Wire Harness, 5-Section, 120V
21-26-19			Wire Harness, 5-Section, 208V
21-26-21			Wire Harness, 6-Section, 208V
21-26-22			Wire Harness, 3-Section, 3 Ph
21-26-23			Wire Harness, 4-Section, 3 Ph
21-26-24			Wire Harness, 5-Section, 3Ph
21-26-25			Wire Harness, 6-Section, 3 Ph
2139		AEROHOT, THURMADUKE	Flanged Inlet (recessed male plug), 1Ph, 120V, NEMA 5-15
2045		AEROHOT, THURMADUKE	Flanged Inlet (recessed male plug), 1Ph, 208V & 240V, 3 & 4 section units, NEMA 6-20
2107		THURMADUKE	Flanged Inlet (recessed male plug), 1 Ph, 208V 5 Section unit, NEMA L6-30
2343		AEROHOT, THURMADUKE	Flanged Inlet (recessed male plug), 3 Ph, 208V & 240V NEMA L15-30
2170		AEROHOT, THURMADUKE	Electric Cord & Plug, 6' long, 1 Ph, 120V
2171		AEROHOT, THURMADUKE	Electric Cord & Plug, 6' long, 1 Ph, 208V & 240V
2321		THURMADUKE	Electric Cord & Plug, 6' long, 1 Ph, 208V & 240V 5 Section
2362		THURMADUKE	Electric Cord & Plug, 6" long, 3 Ph, 208V & 240V
212007		HERITAGE	Bulb, replacement, 60 watt - Cold Pan & Solid Top units
212008		HERITAGE	Bulb, replacement, 40 watt – Frost top units
212155		HERITAGE	Bulb, Replacement, 250 watt, infrared – Hot Food Units
212246		HERITAGE	Socket, Ceramic
212252		HERITAGE	Reflector, Alum, 6-1/2", all units except Hot Food & Hot/Cold

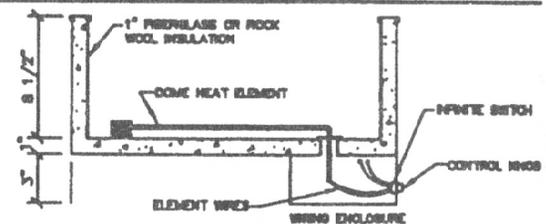
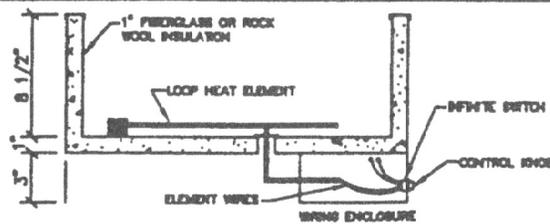
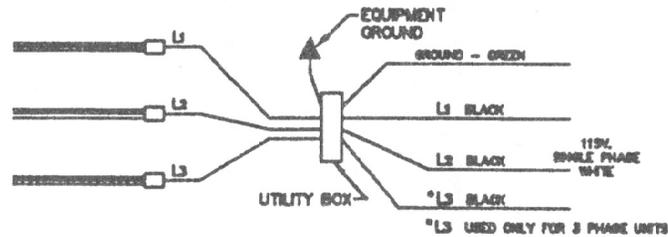
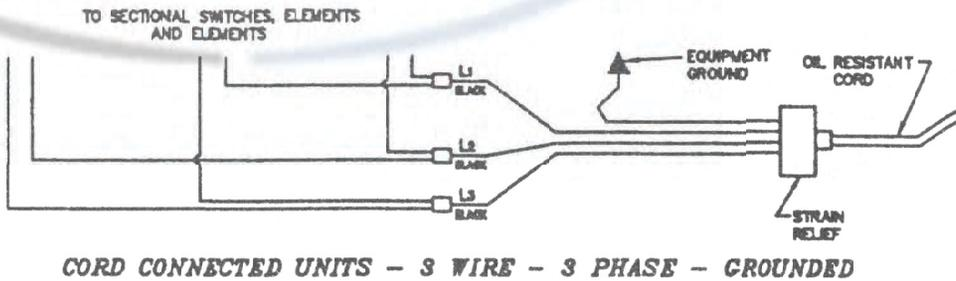
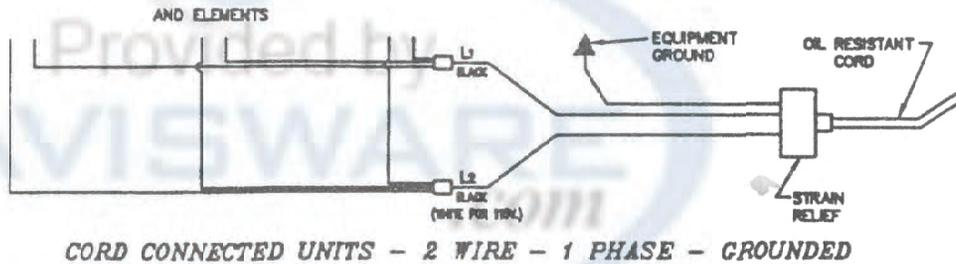
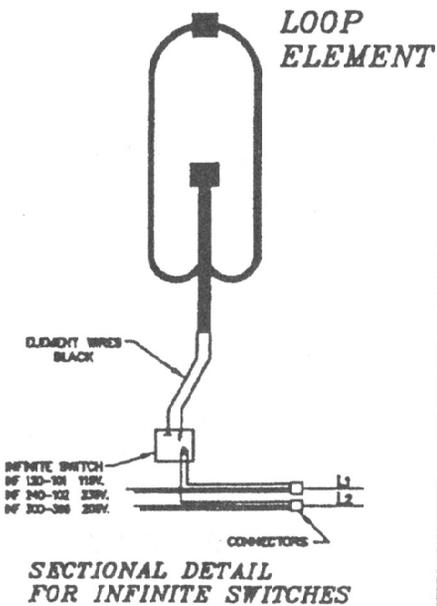
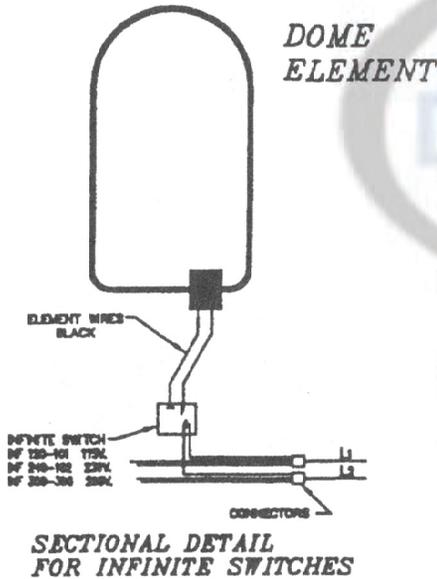

NOTE:
 ON CORD CONNECTED UNITS, CORD IS ATTACHED TO CABINET AT OPERATOR'S RIGHT.
 ON PERMANENTLY CONNECTED MODELS, JUNCTION BOX IS LOCATED UNDER CONTROL PANEL AT OPERATOR'S RIGHT.

CROSS SECTION - SHOWING WIRING & ELEMENTS IN UNITS WITH INFINITE SWITCHES

*DOME
ELEMENT*

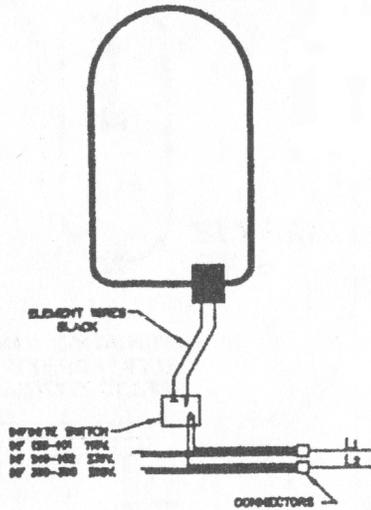

*SECTIONAL DETAIL
FOR INFINITE SWITCHES*

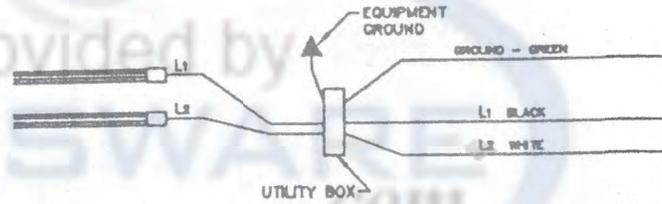

PERMANENTLY CONNECTED UNITS - 115 VOLT, 1 PHASE - GROUNDED

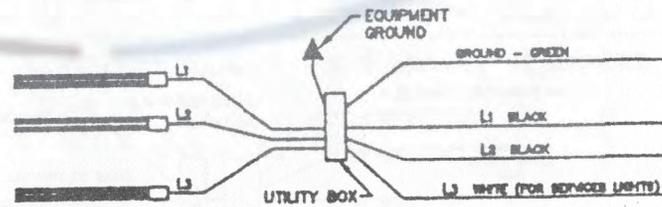

PERMANENTLY CONNECTED UNITS - 208 & 236 VOLT, 1 PHASE - GROUNDED

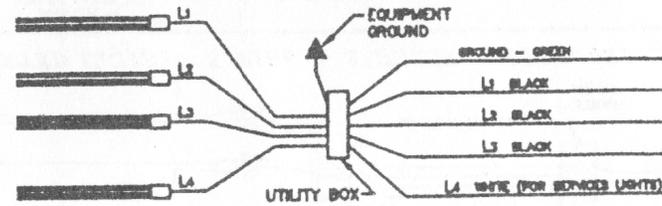

PERMANENTLY CONNECTED UNITS - 208 VOLT, 3 PHASE - GROUNDED

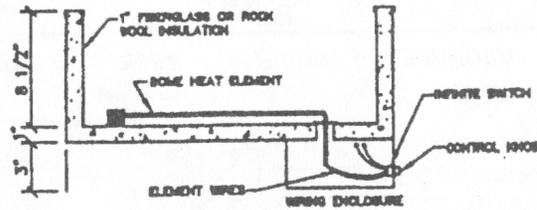

*CROSS SECTION - SHOWING WIRING & ELEMENTS
IN UNITS WITH INFINITE SWITCHES*

NOTE:
ON CORD CONNECTED UNITS, CORD IS ATTACHED FLUSH WITH BOTTOM OF BODY, ON OPERATORS RIGHT AND CENTERED FRONT TO BACK.

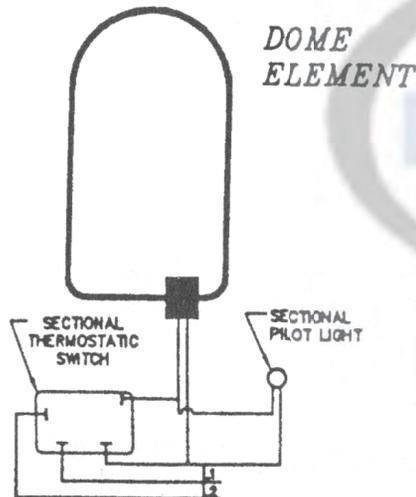

SECTIONAL DETAIL FOR KA-604 AND KA-359 THERMOSTATS

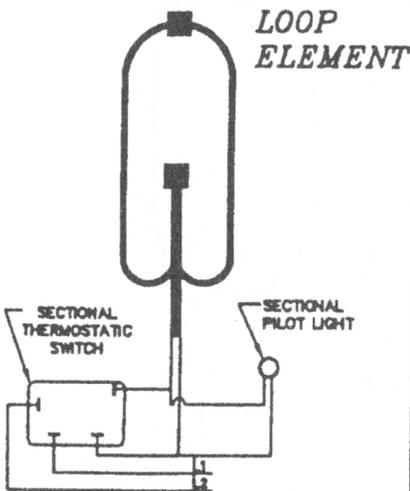

SECTIONAL DETAIL FOR KA-604 AND KA-359 THERMOSTATS

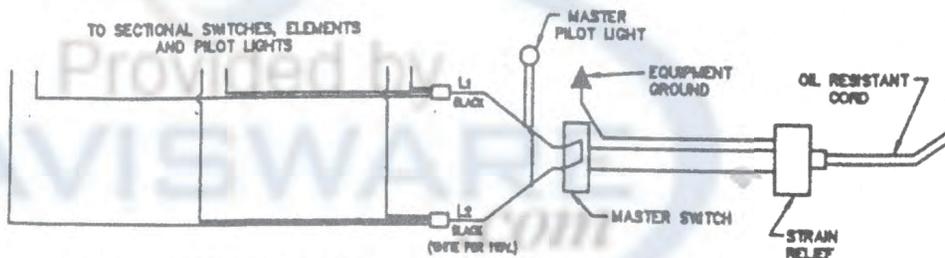

CORD CONNECTED UNITS - 2 WIRE - 1 PHASE - GROUNDED

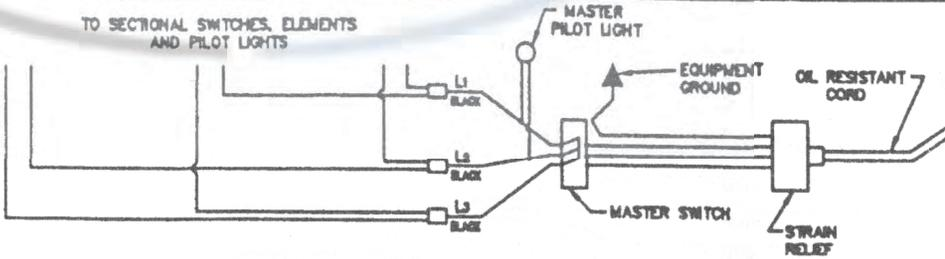

CORD CONNECTED UNITS - 3 WIRE - 3 PHASE - GROUNDED

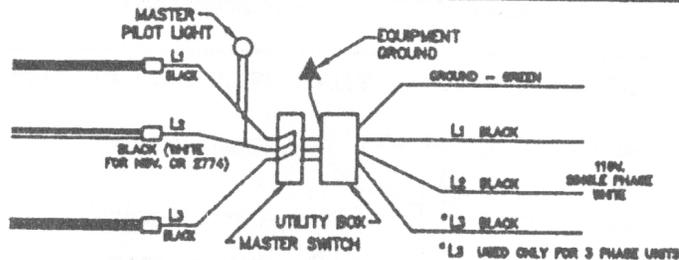

PERMANENTLY CONNECTED UNITS - 1 & 3 PHASE - GROUNDED

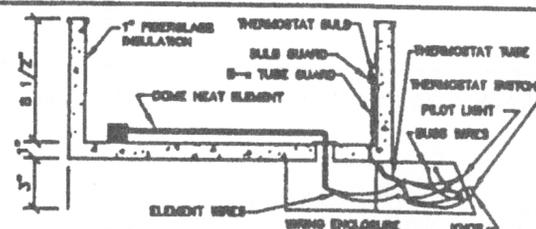
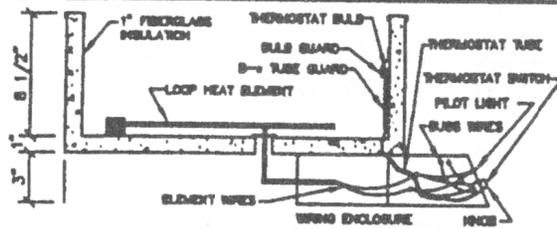

NOTE:
ON CORD CONNECTED UNITS, CORD IS ATTACHED TO CABINET AT OPERATOR'S RIGHT.
ON PERMANENTLY CONNECTED MODELS, JUNCTION BOX IS LOCATED UNDER CONTROL PANEL AT OPERATOR'S RIGHT.

CROSS SECTION - SHOWING ELEMENT AND WIRING IN UNIT EQUIPPED WITH NO. 444 DISH SHELF IN STANDARD AND PORTABLE UNITS THERMOSTATS. PILOTS AND WIRING ARE LOCATED BEHIND FRONT PANEL, BELOW HEATING COMPARTMENT IN AREA ENCLOSED BY DOTTED LINE.

GAS PARTS LIST

Note: Always include Plate Data Specifications when ordering Replacement Parts.

Natural (1000 BTU) • Propane (2500 BTU)

<u>Part #</u>	<u>Product Line</u>	<u>Description</u>
3532	AEROHOT, THURMADUKE	Burner complete with cap – Natural, 1000 BTU per cubic foot, ½” cap
3533	AEROHOT, THURMADUKE	Burner complete with cap – Propane, 2500 BTU per cubic foot, 5/8” cap
3530	AEROHOT, THURMADUKE	Burner valve (for ¼” burner tubing)
3505	AEROHOT, THURMADUKE	Pilot control valve
3511 / 3588	AEROHOT, THURMADUKE	Burner control knob / Gas Burner Knob

Valves for 5/16” burner tubing require conversion kit. Contact factory for details.

3502	THURMADUKE	Burner elbow only
3503	AEROHOT	Brass pilot tip
3504-13	THURMADUKE	Brass pilot tip
3513	THURMADUKE	Pilot tip only
3523-13-04	THURMADUKE	Pilot tube with top for models with #444 dish shelf (approx. 18-1/2” in length)
3524-13-04	THURMADUKE	Pilot tube with tip for models
3525-03-56	AEROHOT	Pilot tube complete with top and screw (8-1/2” long)
3527-02	AEROHOT	Burner tube with elbow (8-1/2”)
3528-02	THURMADUKE	Burner tube with elbow for models without #444 dish shelf
3529-02	THURMADUKE	Burner tube with elbow for models with 3444 dish shelf

PARTS NOT ILLUSTRATED

3501	AEROHOT, THURMADUKE	Gas pressure regulator for Natural Gas
3553	AEROHOT, THURMADUKE	Gas pressure regulator for Propane Gas
3509	THURMADUKE	Thermostatic control only for individual section (BJWA)
3550	THURMADUKE	Knob for thermostatic control (BJWA)
3589 / 3590	AEROHOT, THURMADUKE	Mini pilot/Thermocouple (Need both pieces, as one replacement unit)
3508	AEROHOT, THURMADUKE	Safety pilot valve
2701-9214	AEROHOT THURMADUKE	Radiation and heat distribution plate
3570	AEROHOT	Brass orifice - 1/8”, Wet Bath

AEROHOT FOODSERVICE GAS PARTS DIAGRAM

DAVISWARE.com

PILOT TIP FOR MODELS #302, 303, 304, & #305

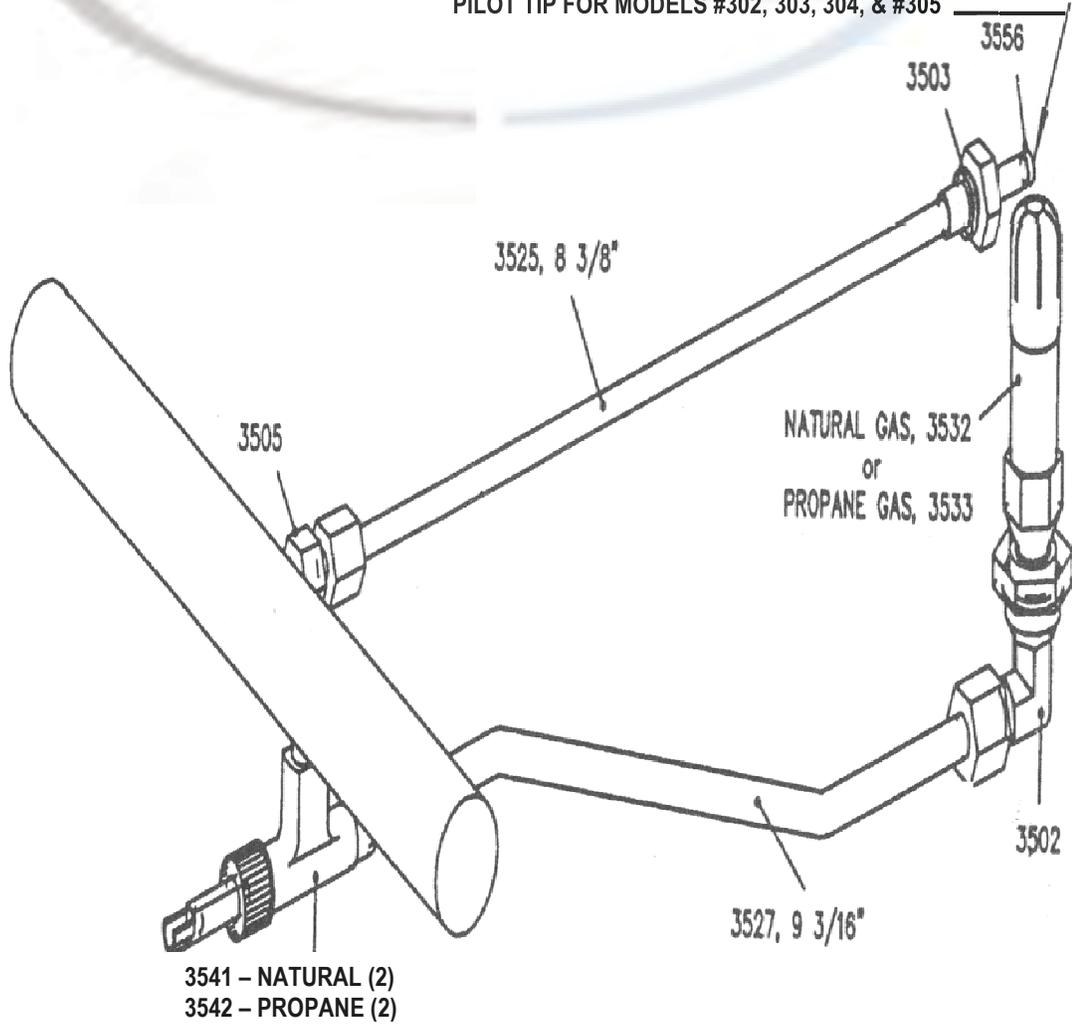

THURMADUKE FOODWARMER GAS PARTS DIAGRAM

