



**Model GC512**



Serial #: \_\_\_\_\_



## **Instruction Manual for Chefmate Slicer Model GC512**

### **For Service on Your Slicer**

1. Visit our website at ***www.globeslicers.com***  
(select the Support / Parts drop down).
2. Or call the Globe service department at 937-297-7247 and ask for contact information for your local service company.

Visit our website for information on additional products available from Globe.

**[www.globeslicers.com](http://www.globeslicers.com)**

***Slicers, Mixers, Vegetable Cutters, Meat Choppers and Scales***

### **- IMPORTANT SAFETY NOTICE -**

This manual contains important safety instructions which must be strictly followed when using this equipment.

# Index

ATTENTION OWNERS AND OPERATORS.....	3
KEY COMPONENTS OF THE SLICER .....	4
CHEFMATE SLICER SAFETY TIPS .....	5
INSTALLATION .....	6-7
OPERATING INSTRUCTIONS.....	8
CLEANING .....	9-10
KNIFE SHARPENING .....	11-12
SIMPLE MAINTENANCE AND REPAIR.....	13-14
TROUBLESHOOTING GUIDE .....	15
LIMITED SLICER WARRANTY .....	16



**GLOBE FOOD EQUIPMENT COMPANY**  
2153 DRYDEN RD.  
DAYTON, OH 45439  
PHONE: 937-299-5493  
TOLL FREE: 800-347-5423  
FAX: 937-299-4147  
E-MAIL: [globeinfo@globeslicers.com](mailto:globeinfo@globeslicers.com)  
WEBSITE: [www.globeslicers.com](http://www.globeslicers.com)

# Attention Owners and Operators

Globe's equipment is designed to provide safe and productive processing of food products as long as the equipment is used in accordance with the instructions in this manual and is properly maintained. Importantly, unless the operator is adequately trained and supervised, there is a possibility of serious injury. Owners of this equipment bear the responsibility to make certain that this equipment is used properly and safely, strictly follow all the instructions contained in this manual and the requirements of local, state or federal law.

Owners should not permit anyone to touch this equipment unless they are over 18 years old, are adequately trained and supervised, and have read and understood this manual. Owners should also ensure that no customers, visitors or other unauthorized personnel come in contact with this equipment. Please remember that Globe cannot anticipate every circumstance or environment in which its equipment will be operated. It is the responsibility of the owner and the operator to remain alert to any hazards posed by the function of this equipment, particularly the sharp knife blade and all moving parts. If you are ever uncertain about a particular task or the proper method of operating this equipment, ask your supervisor.

This manual contains a safety tips section listing a number of precautions to follow to help promote safe use of this equipment. Throughout the manual you will see additional warnings to help alert you to potential hazards.

**Warnings affecting your personal safety are indicated by:**



**Warnings related to possible damage to the equipment are indicated by:**



Make certain the instruction manual is available for easy reference by any operator. Globe has put a warning label in the English language on its slicers. Spanish warning labels are available upon request to Globe. If the warning label or manual becomes misplaced, damaged, or illegible, or if you require additional copies, please contact your nearest representative or Globe directly.

Please remember that this manual or the warnings do not replace the need to be alert, to properly train and supervise operators, and to use common sense when using this equipment.

# Key Components of the Slicer

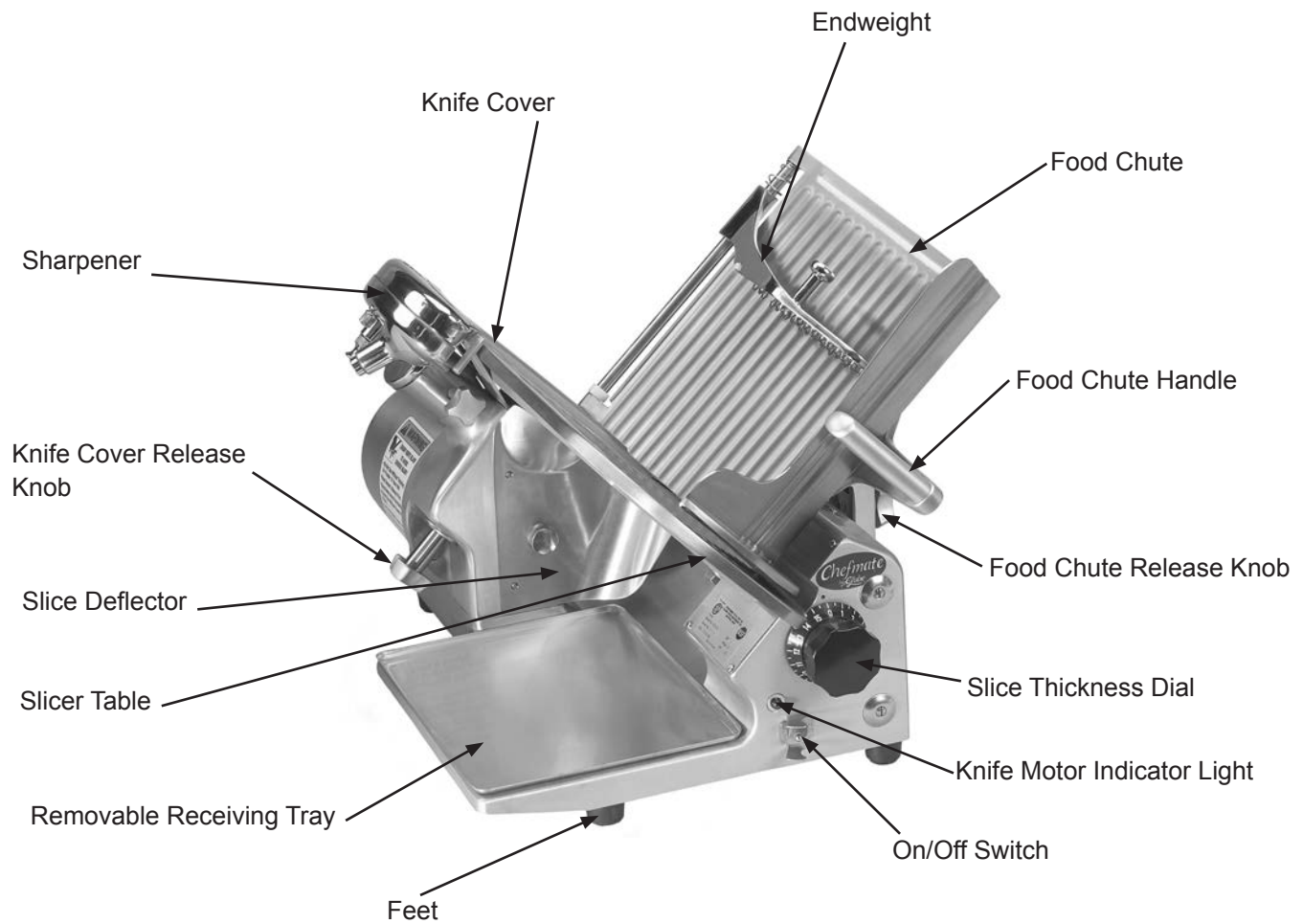

# Chefmate Slicer Safety Tips

 **WARNING**



## SHARP KNIFE BLADE

### TO AVOID SERIOUS PERSONAL INJURY:

- **NEVER** touch this slicer without training and authorization from your supervisor or if you are under 18 years old. Read this instruction manual first.
- **ONLY** install the slicer on a level nonskid surface that is nonflammable and is located in a clean, well-lighted work area away from children and visitors.
- **ALWAYS** ground slicer utilizing proper power source.
- **NEVER TOUCH KNIFE.** Keep hands and arms away from all moving parts.
- **NEVER OPERATE** the slicer without the knife cover and knife ring guard securely installed.
- **NEVER** put hand into the chute arm opening on the right side of the slicer.
- **ONLY USE FOOD CHUTE HANDLE** to push the food chute during slicing.
- **ONLY USE THE Endweight, NOT YOUR HAND,** to hold food products when slicing. Never put your hand on or around food chute when slicer is on.
- **DO NOT CATCH SLICES WITH YOUR HAND.** Let slices drop onto the receiving area.
- **BEFORE CLEANING, SHARPENING, SERVICING, OR REMOVING ANY PARTS,** always turn slicer off, turn the slice thickness dial clockwise until it stops, remove food chute, and unplug power cord.
- **USE ONLY CHEFMATE SLICER ACCESSORIES** properly installed.

# Installation

## **UNPACKING**

1. Unpack the slicer immediately after receipt. If the machine is found to be damaged, save the packaging material and contact the carrier within fifteen (15) days of delivery. Immediately contact your source of the equipment. **You have no recourse to damage after fifteen (15) days.**
2. You should receive with the slicer, rubber feet, warranty card, and an instruction manual. Contact Globe or your local supplier if you did not receive all of these materials.



## **TO AVOID SERIOUS PERSONAL INJURY PROPERLY INSTALL SLICER IN ADEQUATE WORK AREA**

- **ALWAYS** install equipment in a work area with adequate light and space.
- **ONLY** operate the slicer on a solid, level, nonskid surface that is nonflammable.
- **NEVER** bypass, alter, or modify this equipment in any way from its original condition. Doing so may create hazards and will void warranty.
- **NEVER** operate slicer without all knife guards and covers securely installed.
- **NEVER** operate slicer without the warning label attached (see page 4 for location).

## **INSTALLATION**

1. Read this manual thoroughly before installation and operation. **DO NOT** proceed with installation and operation if you have any questions or do not understand anything in the manual. Contact your local representative or Globe **first**.
2. Remove the slicer from the corrugated box.
3. Make sure the rubber feet are firmly tightened.



**NEVER USE SLICER WITHOUT RUBBER FEET INSTALLED.**

4. Select a location for the slicer that has a level, solid, nonskid surface that is nonflammable and is in a well-lighted work area that is away from children and visitors.



**USE AT LEAST TWO PEOPLE TO LIFT THE SLICER UP TO THE OPERATING LOCATION. NEVER ATTEMPT TO LIFT THE SLICER ALONE.**

# Installation

**THIS MACHINE IS PROVIDED WITH A THREE-PRONG GROUNDING PLUG. THE OUTLET TO WHICH THIS PLUG IS CONNECTED MUST BE PROPERLY GROUNDED. IF THE RECEPTACLE IS NOT THE PROPER GROUNDING TYPE, CONTACT AN ELECTRICIAN. DO NOT UNDER ANY CIRCUMSTANCES CUT OR REMOVE THE THIRD GROUND PRONG FROM THE POWER CORD OR USE ANY ADAPTER PLUG (Fig. 7-1 and Fig. 7-2).**

5. Inspect the slicer to ensure all parts have been provided.
6. Make sure the knife cover and sharpener are in place.
7. Make sure the warning label is properly positioned and legible and the instruction manual is available near the slicer.
8. Complete warranty card and mail to Globe or register online at [www.globeslicers.com/warranty.asp](http://www.globeslicers.com/warranty.asp).
9. Clean the slicer using the procedures outlined in the cleaning section (pages 9 and 10) prior to using the slicer.
10. Contact your local representative or Globe directly if you have any questions or problems with the installation or operation of this slicer.



Figure 7-1 Correct



Figure 7-2 **INCORRECT**

# Operating Instructions

**⚠ WARNING**



## SHARP KNIFE BLADE

### TO AVOID SERIOUS PERSONAL INJURY:

- **NEVER** touch this slicer without training and authorization from your supervisor or if you are under 18 years old. Read this instruction manual first.
- **NEVER OPERATE** slicer without knife cover and knife ring guard securely installed. Keep hands and arms away from all moving parts.
- **ONLY USE FOOD CHUTE HANDLE** to push the food chute during manual slicing.
- **ONLY USE THE Endweight, NOT YOUR HAND**, to hold food products when slicing. Never put your hand on or around food chute when slicer is on.
- **DO NOT CATCH SLICES WITH YOUR HAND.** Let slices drop onto the receiving area.
- **BEFORE CLEANING, SHARPENING, SERVICING, OR REMOVING ANY PARTS**, always turn slicer off, turn the slice thickness dial clockwise until it stops, unplug power cord, and remove food chute.

### SLICER OPERATION

1. With the slicer turned off, pull the food chute completely toward you and place the food product on the food chute. Slice only boneless, unfrozen product with the slicer. Use the endweight to hold the food product in place.
2. Make sure all knobs are tightened prior to using the slicer.
3. Rotate the slice thickness dial counterclockwise to the desired slice thickness. After slicing is complete, always turn the slice thickness dial completely clockwise to close the slicer table.
4. Turn slicer on.



**DO NOT hold the food product with your hand. Never put your hand on or around the food chute when the slicer is on. The food chute handle is the only part of the slicer you should touch while slicing.**

5. Use the food chute handle to manually push the food chute back and forth. The food chute handle is the only part of the slicer you should touch while slicing. Do not catch slices with your hand. Let slices drop onto the receiving area.



**If a product needs to be adjusted during slicing, ALWAYS pull the food chute all the way towards you, turn the slicer off, and close the slicer table prior to adjusting the product and the endweight.**

6. After the last slice stroke, pull the food chute all the way towards you. Turn the slicer off and turn the slice thickness dial clockwise until it stops to close the slicer table.

7. Now you can load and unload food product from the food chute.



# Cleaning

## WARNING



## SHARP KNIFE BLADE

### TO AVOID SERIOUS PERSONAL INJURY:

- **BEFORE CLEANING, SHARPENING, SERVICING, OR REMOVING ANY PARTS**, always turn slicer off, turn the slice thickness dial clockwise until it stops, remove food chute, and unplug power cord.
- **NEVER** attempt to clean slicer with the knife running.
- **NEVER** attempt to remove the knife or knife ring guard from the slicer. They must remain on the slicer for proper operation, sharpening, and cleaning.



The entire slicer, including removable parts, must be thoroughly cleaned and sanitized using the procedures identified by your local health department and the ServSafe Essentials published by the National Restaurant Association Educational Foundation (NRAEF). Visit [www.servsafe.com](http://www.servsafe.com) for more details.



It is extremely important to sanitize the slicer and to follow the instructions on your quaternary sanitizer container to ensure proper sanitation is achieved.

## CAUTION

- **DO NOT** put components in dishwasher.
- **DO NOT** hose down or pressure wash any slicer part.
- **DO NOT** use bleach or other caustic/strong detergents on the slicer base or components.

Slicer components are easily disassembled without the use of special tools. It may be desirable to wear non-cutting safety gloves during the cleaning operation.

### DISASSEMBLY & CLEANING

1. Turn the slicer off, turn the slice thickness dial clockwise until it stops so the table covers the knife's edge, and unplug the power cord.
2. Remove the food chute by rotating the food chute release knob (figure 9-1) **ONLY two turns counterclockwise**. Lift the food chute straight up off the support arm (Fig. 9-2).
- **DO NOT turn the food chute release knob more than two turns. Complete removal of the knob will cause the slicer to not operate properly.**
3. The slice deflector can be removed by unscrewing the screw knobs.



Figure 9-1



Figure 9-2

# Cleaning

4. Remove the product receiving tray from the base of the slicer for cleaning.



**BE ALERT. The next steps will expose the knife.**

5. Remove the knife cover by rotating the knife cover release knob counterclockwise until it releases (Fig. 10-1). While holding the knobs on the knife cover, carefully lift the knife cover upward to remove.

NOTE: The slicer will not start with the knife cover removed.

6. Take the food chute, knife cover, and receiving tray back to a three compartment sink. Soak, clean, and scrub the food chute, knife cover, and receiving tray using a mild detergent and warm water solution. Following the instructions on your quaternary sanitizer, soak the food chute, knife cover, and receiving tray in a proper solution of quaternary sanitizer.

**Allow the parts to air dry before reassembling!**



Figure 10-1



**ALWAYS turn slicer off and unplug power cord BEFORE cleaning.**

7. To clean the knife, soak a clean cloth in a mild detergent and warm water solution. Ring out excess water from cloth. **Carefully** wash and rinse the top and bottom (underside) of the knife by wiping from the **center of the knife outward** (Fig. 10-2).



Figure 10-2

8. To clean the knife ring guard, soak a clean cloth in a mild detergent and warm water solution. **Carefully** insert the cloth between the knife and the knife ring guard (Fig. 10-3). While holding the cloth between the knife and the knife ring guard, work it along the entire backside of the knife. A nylon brush could also be used if preferred.

9. To clean the slicer table, soak a clean cloth in a mild detergent and warm water solution. With the slicer table completely closed, wipe the slicer table off by starting at the knife and pulling towards you. Never wipe the slicer table towards the knife.

10. Soak a clean cloth in a mild detergent/warm water solution and finishing cleaning and wiping down the entire slicer.



Figure 10-3

11. Spray both sides of the knife, slicer table, and the entire slicer with a non-bleach, non-chlorine sanitizer following the instructions on your quaternary sanitizer container to ensure proper sanitation is achieved.

**Allow the parts to air dry before reassembling!**

## **REASSEMBLY**

1. Carefully reinstall the cleaned, sanitized, and dry knife cover. Hold the knife cover with one hand while securely tightening the knife cover release knob with the other hand.
2. Place the cleaned, sanitized, and dry food chute back onto the chute arm. Tighten the food chute release knob securely to prevent any “play” between the food chute and the chute arm.
3. Place the cleaned, sanitized, and dry receiving tray back onto the slicer base and plug in the power cord.

# Knife Sharpening

**WARNING**



## SHARP KNIFE BLADE

### TO AVOID SERIOUS PERSONAL INJURY:

- **NEVER** touch rotating knife.
- **ALWAYS** keep hands clear of all moving parts.
- **ALWAYS** turn slicer off and turn slice thickness dial clockwise until it stops, and remove food chute before sharpening.
- **NEVER** sharpen slicer unless all guards are installed.

### WHEN AND HOW OFTEN TO SHARPEN THE KNIFE

1. Symptoms of a dull knife are excess waste/or a “tail” on the unsliced portion remaining in the food chute.
2. The knife needs to be sharpened periodically to provide consistent slices and maximum food product yield. Sharpening the knife lightly every few days is more effective than heavy sharpening at less frequent intervals.

### PREPARING TO SHARPEN

1. Turn the slicer off and turn the slice thickness dial clockwise until it stops so the slicer table covers the knife's edge.
2. Remove food chute from the slicer.
3. Clean and dry both sides of the knife before sharpening, following instructions for knife cleaning on pages 9 and 10.

NOTE: The knife cover must be on during sharpening. The slicer will not start if the knife cover is removed.

4. Loosen the sharpener release knob located at the side of the sharpener (Fig. 11-1). The sharpener will spring to the up position.



Figure 11-1

**!** **BE ALERT. The next step will expose the knife.**

5. Push the sharpener forward (towards the knife) until the knife is centered between the two stones (Fig. 11-2).



Figure 11-2

# Knife Sharpening

6. With the sharpening stones centered over the knife, press down on the sharpener (Fig. 12-1) and while holding it down, lock it into place by retightening the sharpener release knob.



Figure 12-1

## **SHARPENING THE KNIFE - (Regular Procedure)**

1. Start the slicer.
2. Push the grinding stone button #1 (Fig. 12-2) and pull the honing stone button #2 (Fig. 12-2) at the same time so both stones make contact with the knife. Maintain pressure on the buttons for 5-10 seconds.

**TURN SLICER OFF before inspecting.**

## **SHARPENING THE KNIFE - (Extended Procedure)**

**NOTE: Use the extended procedure if the regular sharpening procedure does not produce satisfactory results.**

1. Start the slicer.
2. Push the grinding stone button #1 (Fig. 12-2) so the stone sharpens the back side of the knife. Maintain pressure on the button for 30 seconds.
3. Push the grinding stone button #1 (Fig. 12-2) and pull the honing stone button #2 (Fig. 12-2) at the same time so both stones make contact with the knife. Maintain pressure on the buttons for 5 seconds.



Figure 12-2

**TURN SLICER OFF before inspecting.**

## **AFTER SHARPENING**

1. Turn the slicer off and unplug the power cord.
2. Loosen the sharpener release knob.
3. Pull the sharpener back to its original position.
4. Push down on the sharpener and tighten the sharpener release knob to secure it in place.
5. Clean the entire slicer as described on pages 9 and 10.
6. Reinstall the food chute and plug the power cord in.

# Simple Maintenance and Repair

**WARNING**



## SHARP KNIFE BLADE

### TO AVOID SERIOUS PERSONAL INJURY:

- **ALWAYS** turn off slicer and unplug slicer before servicing.
- **NEVER** touch this slicer without training and authorization from your supervisor.
- **ALWAYS** keep hands clear of rotating knife and moving parts.
- **DO NOT** tamper with, bypass, or remove any safety devices, guards, or switches.
- **ALWAYS** turn off slicer and turn slice thickness dial completely clockwise after each use.
- **USE ONLY Chefmate** parts and accessories properly installed.

### LUBRICATION

Various slicer parts need to be lubricated periodically using Globe oil. Globe oil is a light, tasteless, odorless mineral oil that will not contaminate or impart odors or taste to sliced food products.

**CAUTION**

**DO NOT USE VEGETABLE OIL TO LUBRICATE SLICER.  
VEGETABLE OIL WILL DAMAGE THE SLICER!**

### Food Chute Slide Rod

It is necessary to lubricate the food chute slide rod with Globe oil if the food chute becomes difficult to push.

1. Close the slicer table and unplug the slicer.
2. Pull the food chute completely forward (towards the operator).

NOTE: It is important that the food chute arm is as close as possible towards the operator so the oil reservoir is located under the oil hole (Fig. 13-1).

3. Add several drops of Globe oil into the oil hole (Fig. 13-1)
4. Push the food chute back and forth several times to distribute the oil onto the slide rod.
5. Wipe off excess oil.
6. Plug the slicer in.



Figure 13-1

# Simple Maintenance and Repair

## **CAUTION**

**DO NOT USE VEGETABLE OIL TO LUBRICATE SLICER.  
VEGETABLE OIL WILL DAMAGE THE SLICER!**

### **Sharpener Shafts**

It is necessary to lubricate the sharpener shafts with Globe oil weekly.

1. Loosen the sharpener release knob.
2. Push the sharpener forward and apply oil to the main shaft that the sharpener moves on (Fig. 14-1).
3. Move the sharpener back and forth to distribute the oil.
4. Remove the front cover of the sharpener by unscrewing the knob (Fig. 14-2) until the cover becomes loose and comes off.
5. Put several drops of Globe oil on the shaft behind each sharpening stone.
6. Place the front cover back onto the sharpener and secure it in place.
7. Pull the sharpener back to its original position.
8. Push down on the sharpener and tighten the sharpener release knob to secure it in place.
9. Wipe off any excess oil that drips onto the slicer.

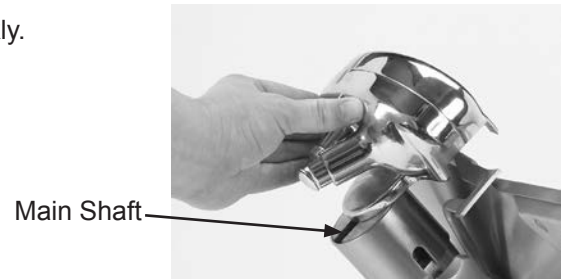

Figure 14-1



Figure 14-2

### **Endweight Slide Rod**

The endweight slide rod should be lubricated weekly or when excessive drag is felt with a few drops of Globe oil.

1. Apply a few drops of Globe oil to the slide rod (Fig. 14-3).
2. Slide the endweight up and down to distribute the oil.

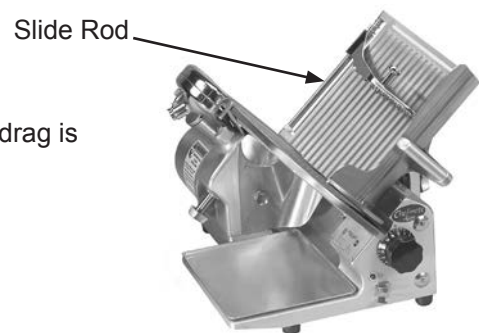

Figure 14-3

**Globe recommends that an authorized Globe service company perform all adjustments and major maintenance.**

**By adequately maintaining your slicer,  
it will provide years of dependable service.**

# Troubleshooting Guide

SYMPTOM	CAUSE	SOLUTION
Slicer will not start	Slicer not plugged in	Plug in slicer
	Switch off	Turn switch on
	Knife cover removed or not properly installed	Install knife cover and tighten the knife cover release knob
Ragged cuts-poor yield	Dull knife	Sharpen knife-make sure knife and stones are clean
	Chipped knife	Sharpen or have new knife installed
	Knife-slicer table gap too wide	Call for service to adjust slicer table
	Knife too small	Have a new knife installed
Metal rubbing knife	Knife cover	Tighten knife cover release knob
	Food chute	Tighten or adjust food chute knob
	Endweight	Have defective endweight replaced
	Slicer table	Call for service to adjust slicer table
Hard to push food chute	No lubrication	Lubricate slide rods thoroughly with Globe oil. <b>DO NOT use vegetable oil!</b>
Hard to sharpen	Stones dirty, wet or clogged with grease	Clean stones with warm water and a brush. Allow stones to air dry. Lubricate shafts with Globe oil afterwards.
	Knife dirty	Clean top and bottom of knife
	Worn stones	Have stones replaced
	Stones not properly aligned	Have sharpener adjusted



# Limited Slicer Warranty

Globe Food Equipment Company ("GFE") warrants to the original purchaser of new equipment that said equipment, when installed in accordance with our instructions within North America and subjected to normal use, is free from defects in material or workmanship for a period of 1 year from installation or 18 months from actual shipment date, whichever date occurs first.

THIS WARRANTY IS IN LIEU OF ALL OTHER WARRANTIES, WHETHER EXPRESSED OR IMPLIED. GFE EXPRESSLY DISCLAIMS ANY IMPLIED WARRANTY OF MERCHANTABILITY OR EXPRESS OR IMPLIED WARRANTY OF FITNESS FOR A PARTICULAR PURPOSE.

GFE'S OBLIGATION AND LIABILITY UNDER THIS WARRANTY IS EXPRESSLY LIMITED TO REPAIRING AND REPLACING EQUIPMENT WHICH PROVES TO BE DEFECTIVE IN MATERIAL OR WORKMANSHIP WITHIN THE APPLICABLE WARRANTY PERIOD. All repairs pursuant to this Warranty will be performed by an Authorized Designated GFE Service Location during normal working hours. IN NO EVENT SHALL GFE BE LIABLE FOR INCIDENTAL OR CONSEQUENTIAL DAMAGES TO BUYER OR ANY THIRD PARTY, INCLUDING, WITHOUT LIMITATION, LOSS OF PROPERTY, PERSONAL INJURY, LOSS OF BUSINESS OR PROFITS OR OTHER ECONOMIC LOSSES, OR STATUTORY OR EXEMPLARY DAMAGES, WHETHER IN NEGLIGENCE, WARRANTY, STRICT LIABILITY, OR OTHERWISE.

This warranty is given only to the first purchaser from a retail dealer. No warranty is given to subsequent transferees.

This warranty does not cover product failures caused by: failure to maintain, neglect, abuse, damage due to excess water, fire, normal wear, improper set up and use. Periodic maintenance including lubrication and sharpening are not covered.

This warranty is not in force until such time as a properly completed and signed installation/warranty registration or an online registration form has been received by GFE within 30 days from the date of installation. Register online at [www.globeslicers.com/warranty.asp](http://www.globeslicers.com/warranty.asp).

THE FOREGOING WARRANTY PROVISIONS ARE A COMPLETE AND EXCLUSIVE STATEMENT BETWEEN THE BUYER AND SELLER. GFE NEITHER ASSUMES NOR AUTHORIZES ANY PERSONS TO ASSUME FOR IT ANY OTHER OBLIGATION OR LIABILITY IN CONNECTION WITH SAID EQUIPMENT.

Example of items not covered under warranty, but not limited to just these items:

1. Acts of God, fire, water damage, burglary, accident, theft.
2. Freight damage.
3. Improper installation or alteration of equipment.
4. Use of generic or after market parts.
5. Repairs made by anyone other than a GFE designated servicer.
6. Lubrication.
7. Expendable wear parts, knife, stones, rubber boots, blown fuses, lamps.
8. Cleaning of equipment.
9. Misuse or abuse.