



Operation Manual  
For  
**Sodir**  
BAR-100 and BAR-200 Toaster



765 Westminster Street • Providence, Rhode Island 02903 • U.S.A.  
Tel: (401) 273-3300 Fax: (401) 273-3328  
[www.equipex.com](http://www.equipex.com) e-mail: [service@equipex.com](mailto:service@equipex.com)





## IMPORTANT SAFEGUARDS

When using electrical appliances, basic safety precautions should always be followed, including the following:

1. Read all the instructions before use.
2. Do not touch hot surfaces; use handles or knobs.
3. To avoid electric shock, **do not immerse the power cord, or any part of the unit**, in any liquid.
4. Close supervision is necessary when any appliance is used, especially around children.
5. Unplug appliance from the electrical outlet when not in use, and before cleaning. Allow appliance to cool before installing or removing any parts or accessories, and before cleaning.
6. Do not operate any appliance with a damaged cord or plug, or if appliance should sustain damage, or malfunction in any way. In this event, return appliance to the nearest authorized service facility for examination, repair or adjustment.
7. The use of accessories and/or attachments not recommended by the appliance manufacturer may cause injury or damage to the appliance, and may void your warranty.
8. Do not use outdoors.
9. Do not allow the power cord to hang over the edge of a table or counter, or to be exposed to hot surfaces, as damage may occur.
10. Do not place appliance on or near a burner, or in a heated oven.
11. To disconnect an appliance, **first** turn all controls to the 'off' position; *then* unplug the power cord from the wall outlet.
12. Do not use appliance other than for its intended use.
13. SAVE THESE INSTRUCTIONS FOR LATER USE!

## INTRODUCTION

The **SODIR** Model # BAR-100 and # BAR-200 countertop snack toasters offer speedy toasting and finishing. The units are designed for commercial applications, especially when small footprint is an issue. The snack toasters are constructed of stainless steel and are equipped with quartz heating elements, a 4-position switch, a 15-minute timer with hold position and a red pilot light. Model # BAR-100 comes with one wire rack, while # BAR-200 comes with two wire racks. Each unit is equipped with an easily removable rack handle.

### *Specifications:*

<b>Model</b>	<b>Electrical</b>	<b>Plug Configuration</b>
BAR100/1	120V, 1PH, 1.7KW, 14A	NEMA-5-15P
BAR100	208/240V, 1PH, 1.7KW, 7/8A	NEMA-6-15P
BAR200	208/.240V, 1PH, 2.6KW, 11/13A	NEMA-6-15P

## INSTALLATION

The **SODIR** snack toasters need to be connected to a grounded outlet of proper voltage (208/240V or 120V) depending on the model. **DO NOT** place the unit in a damp area or near steam source. Make sure that the back panel of the snack toaster is not blocked.

## OPERATION

The snack toasters are simple to operate. Turn the toaster on by rotating the switch to one of the three following positions: "ALL ELEMENTS ON", "TOP ELEMENTS ON", or "BOTTOM ELEMENTS ON". Turn the timer knob clockwise to select the desired time. By turning the timer knob to the "HOLD" position indicated by the marking "C" on the time dial, operate the unit in continuous mode. To take the wire rack out of the toaster, attach the handle provided with the unit to it. Always use the drip tray.

The **SODIR** snack toasters can be used for a wide variety of foods. Cooking times will vary depending on food products and desired results.

## CLEANING

**WARNING: Disconnect (unplug) electrical power supply before cleaning**

**CAUTION: Do not spray quartz heating elements with any liquid while they are hot**

Cleaning is very important in maintaining a safe and well working machine. Allow the metal surfaces to cool down sufficiently in order to safely handle it. After the unit has cooled, remove the wire rack using the handle and the drip tray. Clean these items in pot sink using standard cleaning detergents. The housing, heating elements and the back cover should be cleaned using a cloth lightly dampened with a clean soapy solution. Use a clean lint-free cloth to remove the excess water or soap.

**DO NOT** spray the housing with any liquid

**DO NOT** wash the unit under running water

**DO NOT** allow water to drip into the housing around the electrical components

**DO NOT** spray hot elements with any liquid

Inspect all parts on a regular basis to ensure that all parts are in good working order. If a part is damaged, have the unit repaired by an authorized service agency prior to returning the unit to operation. If you have trouble locating a service agency in your area, call **EQUIPEX, LTD.** at 1-800-649-7885 and ask for customer service.

## SODIR SNACK TOASTERS

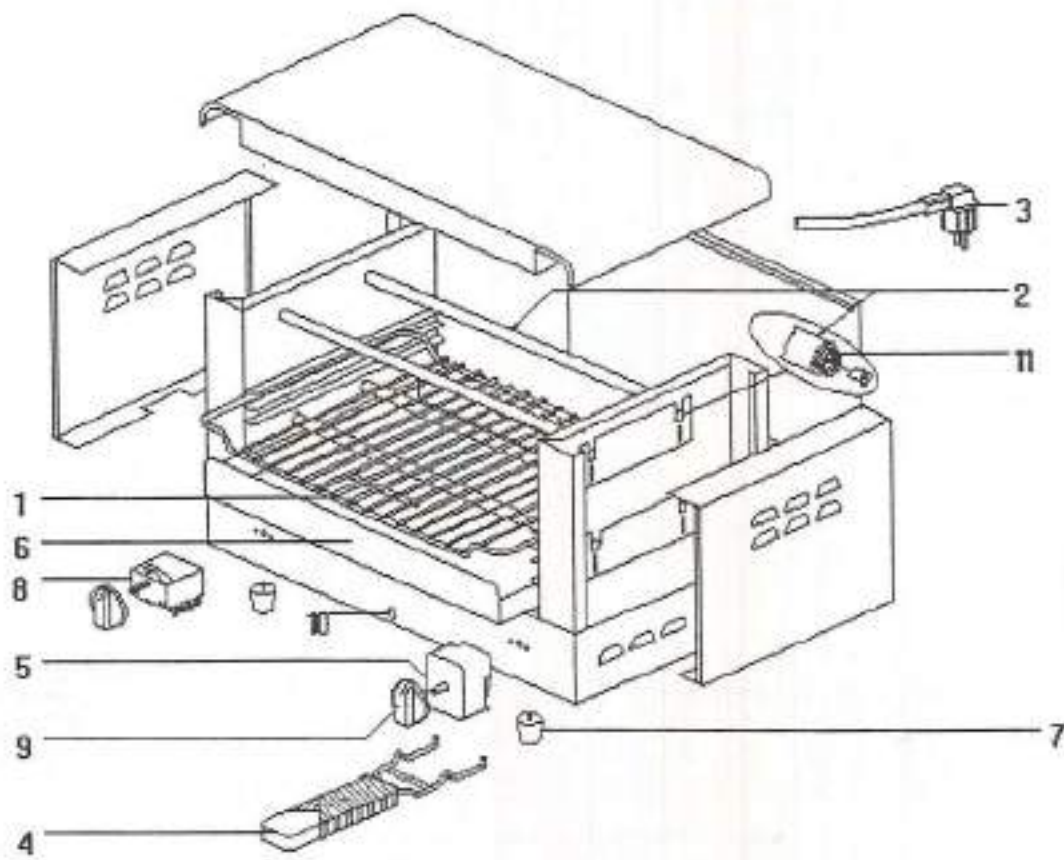

**MODEL BAR100**



EQUIPEX, LTD.		11-Dec-00		SPBAR-100-03	
765 Westminster Street, Providence, RI 02903					
tel: (401) 273-3300		fax: (401) 273-3328		EFFECTIVE FEB. 2004 Toll free: 1-800-649-7885	
SODIR Model BAR 100 Snack Toaster (120V/60/1 Phase) / BAR 100 Snack Toaster (208-240V/60/1 Phase)					
Drawing #	Part Number	Quantity	Description	Old Part Number	
1	F01011	1	Wire Shelf	P-S117001	
2	D04005	4	Quartz Tube	P-S601011	
3	OEM0011	1	Power Cord, 120V (no plug)	n/a	
3	OEM0012	1	Power Cord, 220V (no plug)	n/a	
4	F01025	1	Handle	P-S601025	
5	A02008	1	Timer	P-S102001	
6	300091208	1	Crumb Tray	P-S544108	
7	A13001	4	Foot	P-S113001	
8	A01001	1	Rotary Switch	P-S101001	
9	A14042BAR	2	Knob	P-S114029	
10	A08002	1	Red Pilot Light, 120V	P-S108005	
10	A08008	1	Red Pilot Light, 220V	P-S108015	
11	D01043	4	Heating Element, 120V	n/a	
11	D01003-220	4	Heating Element, 220V	P-S401003	
	A09003	8	Steatite/Insulator	n/a	

Post-it® Fax Note		7671	Date	# of pages ▶
To	<i>Crystal</i>		From	<i>Ronni</i>
Co./Dept.			Co.	
Phone #			Phone #	
Fax #	<i>415-821-2178</i>		Fax #	

## SODIR SNACK TOASTERS

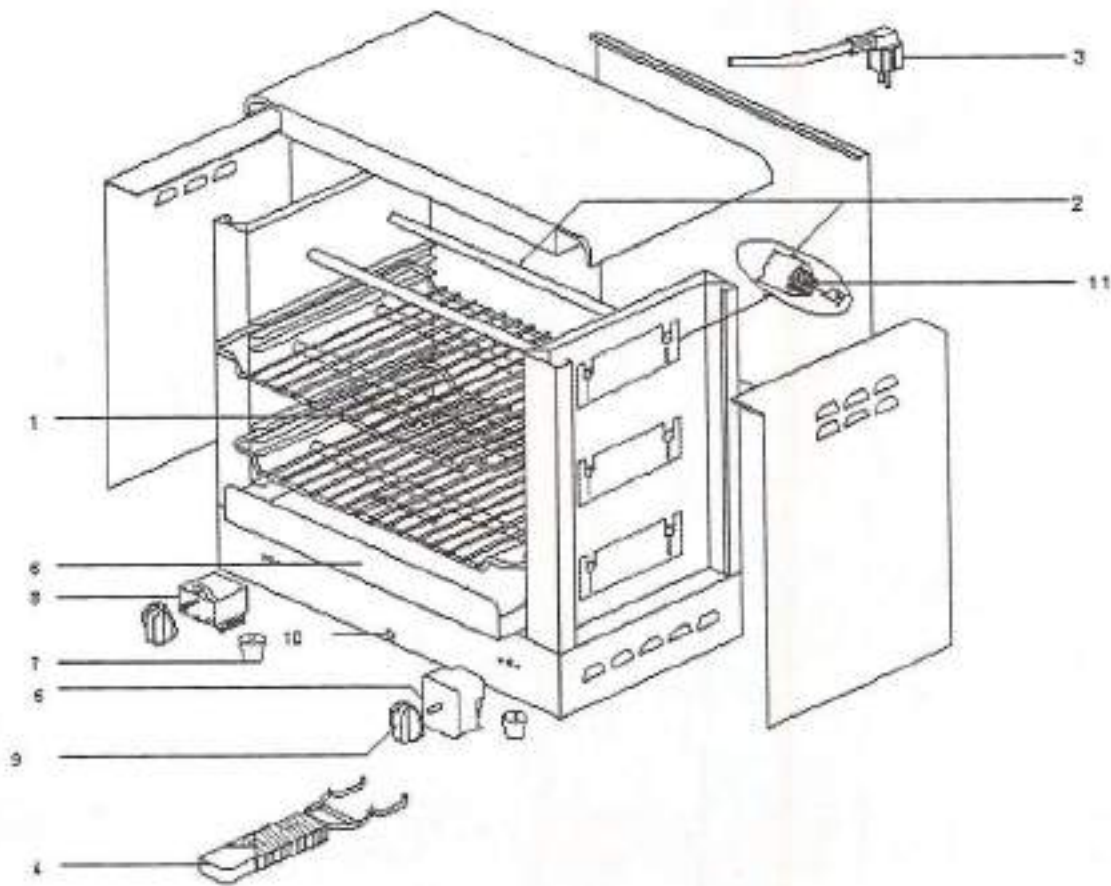

**MODEL BAR200**

EQUIPEX, LTD.			11-Dec-00	SPBAR-200-03
765 Westminster Street, Providence, RI 02903				
tel: (401) 273-3300		fax: (401) 273-3328	Effective Feb. 2004	Toll free: 1-800-649-7885
SODIR Model BAR 200 Snack Toaster (208-240V/60/1 Phase)				
Drawing #	Part Number	Quantity	Description	Old Part Number
1	F01011	2	Wire Shelf	P-S117001
2	D04005	6	Quartz Tube	P-S601011
3	OEM0012	1	Power Cord, 220V (no plug)	n/a
4	F01025	1	Handle	P-S601025
5	A02008	1	Timer	P-S102001
6	30009I208	1	Crumb Tray	P-S544108
7	A13001	4	Foot	P-S113001
8	A01001	1	Rotary Switch	P-S101001
9	A14042BAR	2	Knob	P-S114029
10	A08008	1	Red Pilot Light, 220V	P-S108015
11	D01003-220	6	Heating Element, 220V	P-S401003
	A09003	12	Steatite/Insulator	n/a



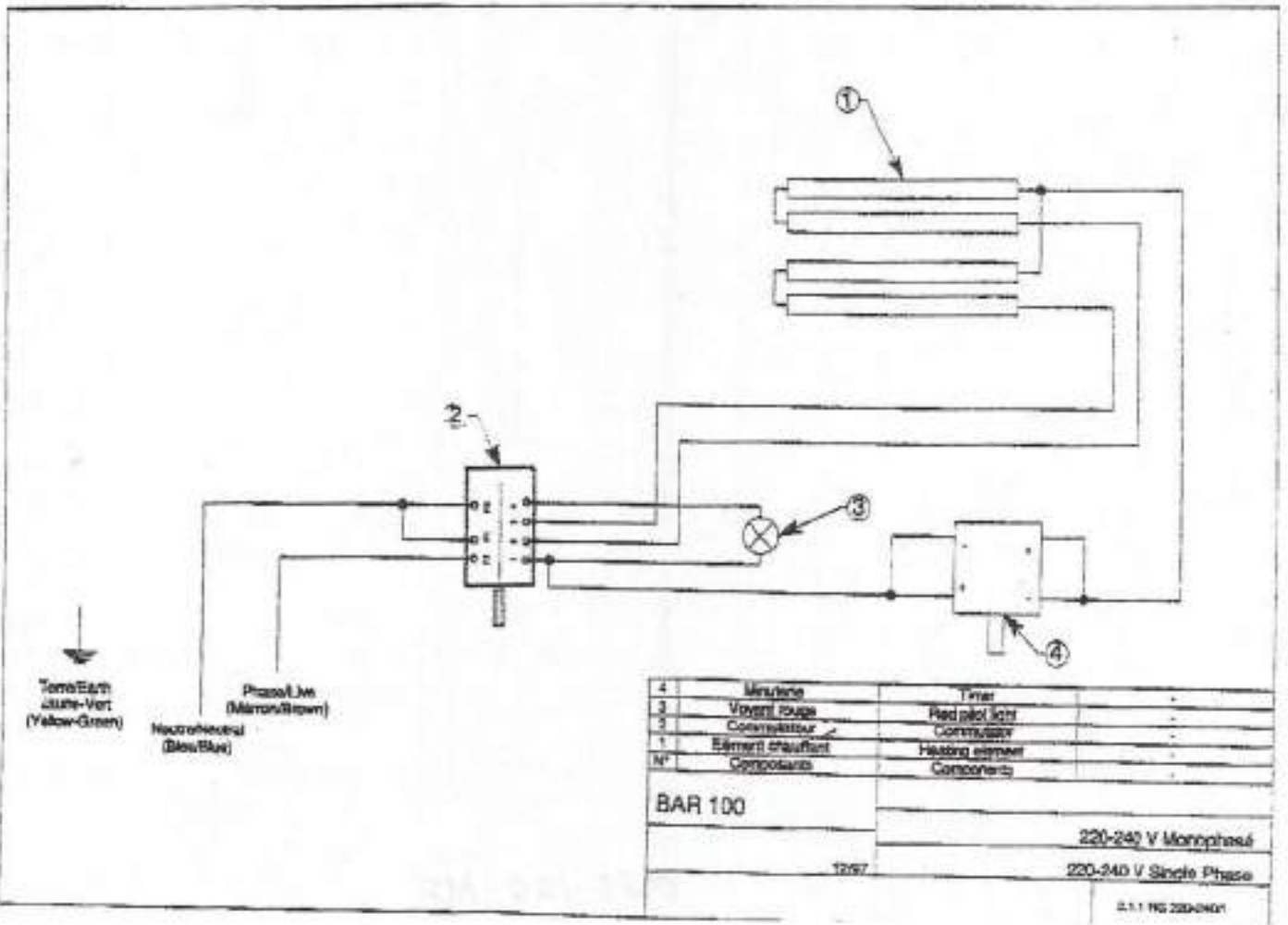
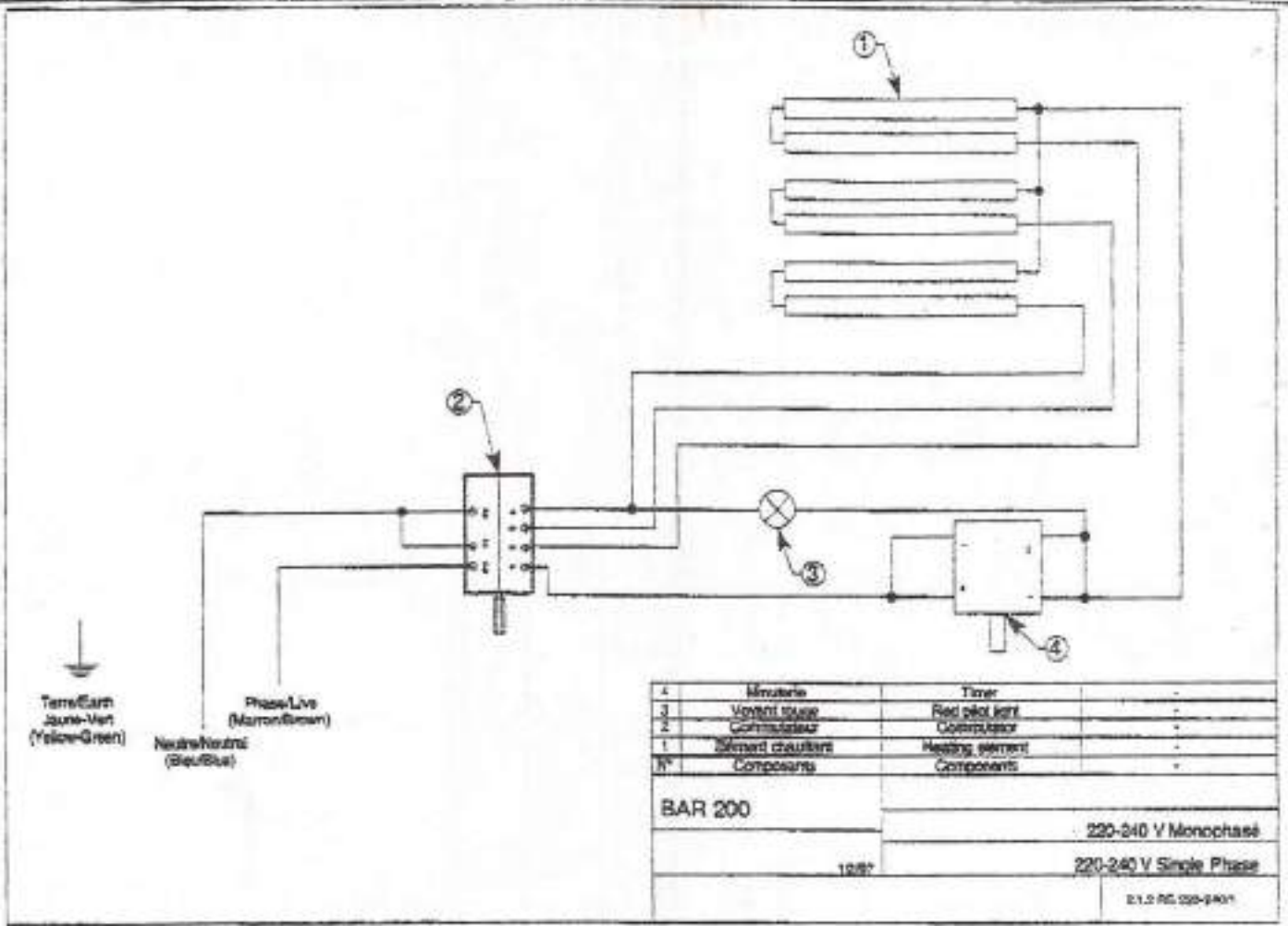



## LIMITED WARRANTY

Your new **EQUIPEX** product is warranted to the original purchaser for a period of one year from the date of purchase.

This limited warranty is against defects from original factory imperfections in material and/or workmanship and includes labor for replacement of defective parts, provided repairs are performed by an authorized service agency. Our obligation under this warranty is limited to repairing or replacing any part or parts thereof. The CUSTOMER must inform the Service Agency of warranty coverage and provide a copy of the dated sales or delivery receipt BEFORE WARRANTY REPAIRS BEGIN. Replacement parts and accessories are warranted for ninety (90) days from the date of purchase when purchased separately and will be verified by dated sales receipt or packing slip for that item. All parts or accessories replaced under warranty must be returned to the Service Agency.

This warranty applies only to equipment under normal use and service in the U.S.A. and Canada. It does not apply to any item which has been repaired or altered in any way so as, in the judgment of EQUIPEX, to affect its reliability.

### **THE FOLLOWING ARE NOT COVERED UNDER WARRANTY:**

1. Damage caused by abuse, misuse or dropping or other similar incidental damage caused by, or as a result of, customer failure to follow assembly, operation, cleaning, user maintenance or storage instructions.
2. Labor to replace inoperative parts such as bulbs, plugs or racks due to normal wear and tear or abuse.
3. Materials or labor to repair scratched, stained, chipped, pitted, dented or discolored surfaces, attachments or accessories.
4. Transportation charges to or from a service agency for repair of your machine. If you should have questions relating to this issue, please call **Equipex** at 1-800-649-7885.
5. Labor charges to install or test attachments or accessories, which are replaced for any reason.
6. SHIPPING DAMAGES. Visible and hidden damages are the responsibility of the freight carrier. The consignee must file the claim promptly against the carrier. KEEP ALL ORIGINAL CONTAINERS AND PACKAGING MATERIAL FOR CARRIER INSPECTION.
7. Products placed or stored in the equipment are not subject to this warranty and no responsibility is assumed thereof.

**THIS WARRANTY IS GIVEN EXPRESSLY AND IN LIEU OF ALL OTHER WARRANTIES, EXPRESSED OR IMPLIED, FOR MERCHANTABILITY AND FOR FITNESS TOWARD A PARTICULAR PURPOSE AND CONSTITUTES THE ONLY WARRANTY MADE BY EQUIPEX, LLC. IT NEITHER ASSUMES, NOR AUTHORIZES ANY PERSON TO ASSUME FOR US, ANY OTHER LIABILITY IN CONNECTION WITH THE SALE OF THE SUBJECT EQUIPMENT.**

For service, please call **EQUIPEX** at 1-800-649-7885, menu option # 3

765 Westminster Street • Providence, Rhode Island 02903 • U.S.A.

Tel: (401) 273-3300

Fax: (401) 273-3328

[www.equipex.com](http://www.equipex.com)

e-mail: [service@equipex.com](mailto:service@equipex.com)